

Clean Design Manifold Valve

Low fluid accumulation Easy to clean

New



IP69K

Large flow rate

1,600^{*1} L/min (ANR)

Enclosure: IP69K

NSF-H1 grease

External parts: FDA-compliant materials^{*2}

Metal parts are made of stainless steel 316 with high anti-corrosion performance.

Wiring: Lead wire/
Fieldbus type
 IO-Link

*1 When the inlet side is 0.6 MPa, and the outlet side is 0.5 MPa (20°C)

*2 The lead wire type cable is not made of FDA-compliant materials.



The photo shows the IO-Link compatible manifold.

Crevice free exterior and can be
cleaned without disassembly
Cleanable space between valves



Valve width is **15 mm**.

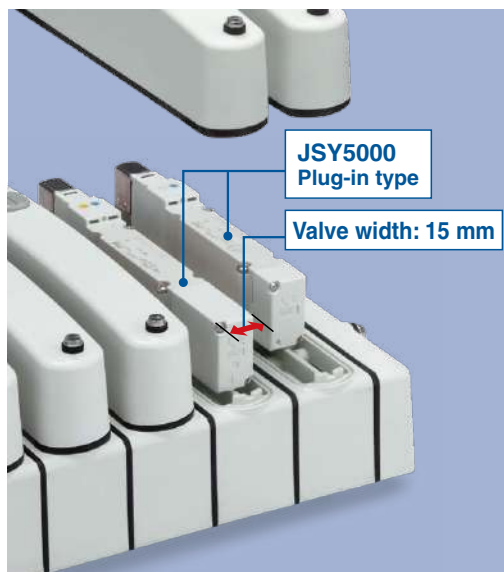

Sub-plate (Single unit)

IP69K compliant



JSY5000-H Series



CAT.ES11-117A

Wiring

Manifold valve

Lead wire type



Fieldbus type

IO-Link

M12 connector

SI unit EX430 p. 32

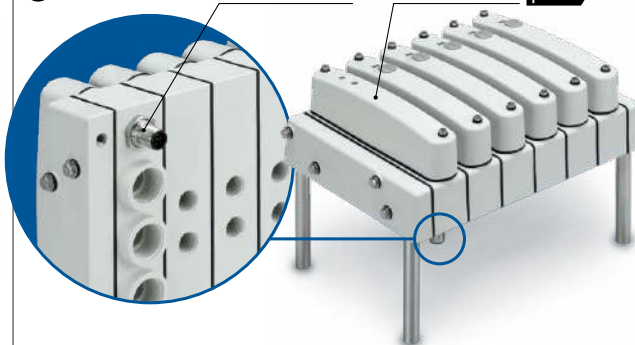

Sub-plate (Single unit)

M12 connector cable



Manifold Parts

Mounting leg

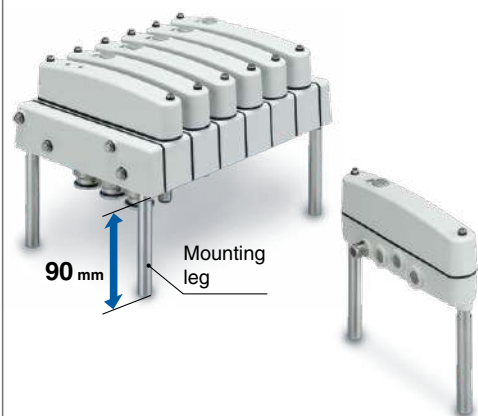

With One-touch fittings



5-port type

Manifold block assembly p. 27

When the same manifold is used for different pressures, a manifold block assembly is used as a supply port for different pressures. It is also used for independent exhaust.

* Use with blocking disks.

Without fitting

With fittings

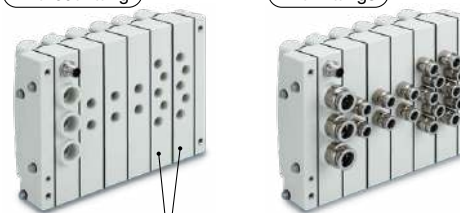

5-port type manifold block

Series Variations

Variations	4(A), 2(B) port size								Rated voltage	Wiring		
	G1/4 (Without fitting)	One-touch fitting								Common specifications		
		Screw fitting								Positive common	Negative common	
		ø8		ø10		ø5/16"		ø3/8"				
	Brass	Stainless steel	Brass	Stainless steel	Brass	Stainless steel	Brass	Stainless steel				
Plug-in Lead wire type (34 cores) p. 11	●	●	●	●	●	●	●	●	24 VDC	●	●	
Plug-in Fieldbus type IO-Link p. 11	●	●	●	●	●	●	●	●	24 VDC	—	●	
Sub-plate type p. 19	●	●	●	●	●	●	●	●	24 VDC	●	●	

● Standard ○ Option ▲ Made to order

Manifold Options

■ Blanking plate [With two mounting screws] p. 34

Used when valve additions are expected or for maintenance

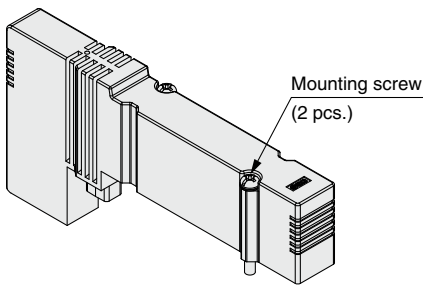

JSY51M-26P-1A

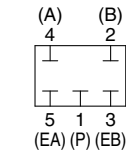

Circuit diagram

■ SUP/EXH blocking disk p. 34

[SUP blocking disk]

By inserting the SUP blocking disk in the pressure supply passage of the manifold valve, can provide two different high and low pressure in one manifold.

[EXH blocking disk]

By inserting the EXH blocking disk in the exhaust passage of the manifold valve, can separate the exhaust from the valve so it does not affect the other valves. It can also be used for the manifold for the positive pressure and vacuum mixed manifold. (2 pieces are required to block EA/EB both sides of the EXH.)

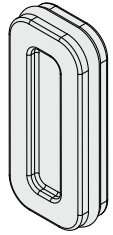

Series	SUP blocking disk	EXH blocking disk
JSY5000	JSY51M-40P-2A	JSY51M-40P-2A

■ Tube releasing tool p. 33

This tool is used for removing the tube from port A and B.

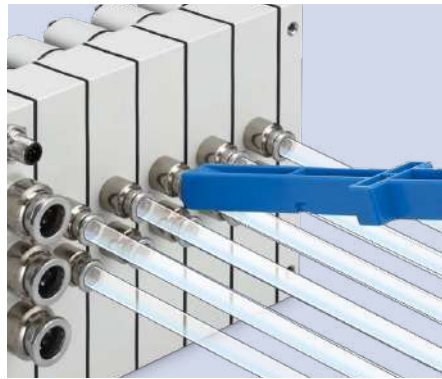
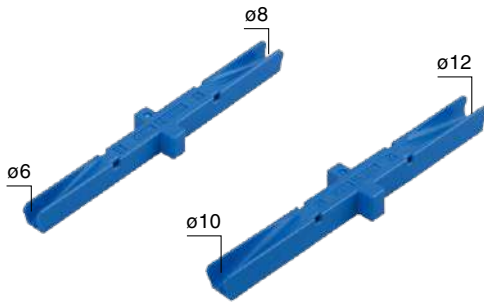

Applications

Installed inside equipment

Installed near actuators

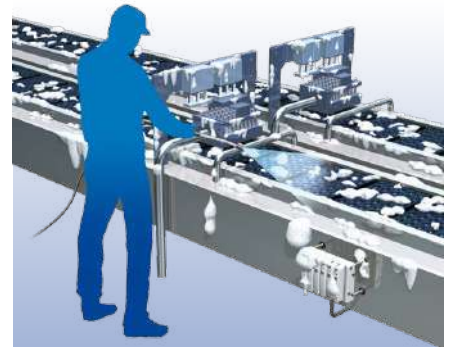

	Manifold options		Valve options	
	Blanking plate	SUP/EXH blocking disk	Vacuum/ Low pressure specification	Reverse pressure
	○ p. 34	○ p. 34	▲ External pilot	▲ External pilot
	○ p. 34	○ p. 34	▲ External pilot	▲ External pilot
	—	—	▲ External pilot	▲ External pilot

IP69K manifold

IP69K products are IP6X (IEC/EN 60529) and IPX9K (ISO 20653) compliant and protected against dust and high-pressure hot water.



Glossary of Terms

IP6X: Dust-tight

IPX9K: High-pressure and temperature jet wash

Not adversely affected under the following conditions.

Sample placed on a turntable and rotated at a speed of 5 ± 1 rpm. Hot pressurized water at $80 \pm 5^\circ\text{C}$ and pressure 8 to 10 MPa is then sprayed onto the sample at a distance of 100 to 150 mm with a jetwash nozzle from four position: 0° , 30° , 60° , and 90° , for 30 s for each position. Flow rate: 15 ± 1 L/min

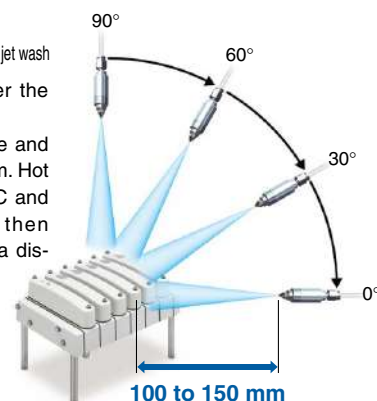

Related Products

EHEDG Compliant Fittings

EHEDG Compliant

IP69K

Hygienic Design

FDA Compliant



KFG2H□-E Series

* This product is not assembled when shipped.



EHEDG Certification

This series satisfies EHEDG guidelines (hygienic design standards), preventing liquid and foreign matter from entering, and is easy to wash.

Design for less residual liquid accumulation



EHEDG compliant fitting

Design for better liquid flow and less residual liquid accumulation

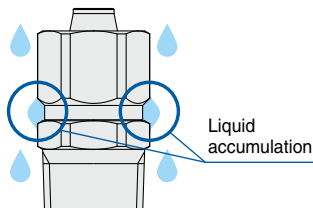

Existing KFG2 model

Design for poor liquid flow and more residual liquid accumulation

Achieved IP69K rating

Rubber parts

The material used is a special FKM that is compliant with the FDA (U.S. Food and Drug Administration) §177.2600 dissolution test. They are colored in blue for superior visibility.

Body type: Male connector

Connection thread: M, G*1

*1 ISO 16030 compliant

Fluid temperature

-5 to 150°C

EHEDG design standards

- 1 External surface roughness: Ra 0.8 μm or less
- 2 Corners of radius 3 mm or more or with an internal angle of 135°
- 3 Stainless material with high anti-corrosion performance: Stainless steel 316
- 4 No direct contact of external metal parts
- 5 Gasket seals made of FDA-compliant rubber materials



EHEDG Certificate of Compliance

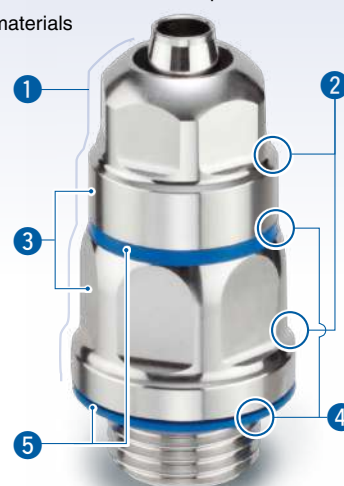

Related Products

Clean Design Fittings

*1 This product is not assembled when shipped.



Hygienic Design

FDA Compliant

Stainless Steel 316 Insert Fittings
KFG2H□-C Series



FDA Compliant Fittings



FDA Compliant



Stainless Steel 316 One-touch Fittings
KQG2-F Series



Metal One-touch Fittings
KQB2-F Series



Stainless Steel 316 Insert Fittings
KFG2-F Series

FDA (U.S. Food and Drug Administration) Compliant Tubing

FDA Compliant

Polyurethane Tubing TU-X214



- Complies with the FDA (U.S. Food and Drug Administration) § 177.2600 dissolution test
- Complies with the EU No 10/2011 dissolution test

Metric size	Color
ø4, ø6, ø8, ø10, ø12	Black, White, Red, Blue, Yellow, Green, Clear, Orange

Fluoropolymer Tubing TL/TIL



- Complies with the FDA (U.S. Food and Drug Administration) § 177.1550 dissolution test
- Food Sanitation Law compliant*1

Metric size	Inch size	Color
ø4, ø6, ø8, ø10, ø12, ø19	ø1/8", ø3/16", ø1/4", ø3/8", ø1/2", ø3/4", ø1"	Translucent

Fluoropolymer Tubing (PFA) TLM/TILM

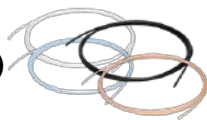

- Complies with the FDA (U.S. Food and Drug Administration) § 177.1550 dissolution test
- Food Sanitation Law compliant*1

Metric size	Inch size	Color
ø2, ø3, ø4, ø6, ø8, ø10, ø12, ø16, ø19, ø25	ø1/8", ø3/16", ø1/4", ø3/8", ø1/2", ø3/4", ø1", ø1 1/4"	Translucent, Black, Red, Blue

FEP Tubing (Fluoropolymer) TH/TIH



- Complies with the FDA (U.S. Food and Drug Administration) § 177.1550 dissolution test
- Food Sanitation Law compliant*1

Metric size	Inch size	Color
ø4, ø6, ø8, ø10, ø12	ø1/8", ø3/16", ø1/4", ø3/8", ø1/2", ø3/4"	Translucent, Black, Red, Blue

Soft Fluoropolymer Tubing TD/TID



- Complies with the FDA (U.S. Food and Drug Administration) § 177.1550 dissolution test
- Food Sanitation Law compliant*1

Metric size	Inch size	Color
ø4, ø6, ø8, ø10, ø12	ø1/8", ø3/16", ø1/4", ø3/8", ø1/2"	Translucent

Polyolefin Tubing TPH



- Complies with the FDA (U.S. Food and Drug Administration) § 175.300 dissolution test

Metric size	Color
ø4, ø6, ø8, ø10, ø12	White, Blue, Yellow

Soft Polyolefin Tubing TPS



- Complies with the FDA (U.S. Food and Drug Administration) § 175.300 dissolution test

Metric size	Color
ø4, ø6, ø8, ø10, ø12	White, Blue, Yellow

*1 Testing in compliance with Japan's Food Sanitation Law based on the 370th notice given by the Ministry of Health and Welfare in 1959

CONTENTS

Valve Specifications	p. 6
Valve Specifications (JSY5000-H Plug-in Type)	p. 6
Manifold Specifications	p. 7
Manifold Flow Rate Characteristics/Weight	p. 7
Valve Weight	p. 7
Response Time	p. 7
Connector Wiring Layout	p. 7
Valve Construction	p. 8
Valve Replacement Parts: Pilot Valve	p. 9

Manifold

**Clean Design
Manifold Valve**

JSY5000-H Series [IP69K Compliant]



p. 11

How to Order Manifolds	p. 11
How to Order Valves	p. 12
Dimensions: Lead Wire Type	p. 13
Electrical Wiring Specifications	p. 14
Dimensions: Fieldbus Type (IO-Link)	p. 15
Dimensions: 5-Port Type Manifold Block [Common to Lead Wire Type/Fieldbus Type (IO-Link)]	p. 16
Dimensions: Panel Cutout Dimensions	p. 17
Dimensions: External Pilot (Made to Order)	p. 18

Sub-plate

Sub-plate (Single Unit)

[IP69K Compliant]



p. 19

Sub-plate Specifications	p. 19
Sub-plate Flow Rate Characteristics/Weight	p. 19
How to Order Sub-plates (With Valve/Valve Cover)	p. 20
Dimensions: Sub-plate	p. 21

Manifold Exploded View	p. 23
Lead Wire Type	p. 23
Fieldbus Type	p. 24
Manifold Exploded View (Common Parts)	p. 25
Manifold Parts Nos.	p. 26

Sub-plate (Single Unit) Exploded View	p. 31
Sub-plate Parts Nos.	p. 31

Fieldbus System: For Output EX430 Series	p. 32
One-touch Fittings, Plugs, Tube Releasing Tools	p. 33
Manifold Options	p. 34
Made to Order	p. 35

JSY5000-H Series: Specific Product Precautions	p. 36
EX430 Series: Specific Product Precautions	p. 40

JSY5000-H Series Valve Specifications

Valve Specifications (JSY5000-H Plug-in Type)

Valve type		Rubber seal	
Fluid		Air	
Internal pilot operating pressure range MPa	2-position single	0.15 to 0.7	
	2-position double	0.1 to 0.7	
	3-position	0.2 to 0.7	
	4-position dual 3-port valve	0.15 to 0.7	
External pilot (Made to order) operating pressure range MPa	Operating pressure range		-100 kPa to 0.7
	Pilot pressure range	2-position single	0.25 to 0.7
		2-position double	
		3-position	
Ambient and fluid temperatures*1 °C		-10 to 50 (No freezing)	
Max. operating frequency Hz	JSY5000	2-position single/double	5
		4-position dual 3-port valve	3
		3-position	3
Manual override		Non-locking push type	
Pilot exhaust type	Internal pilot	Common exhaust	
	External pilot (Made to order)		
Lubrication		Not required	
Mounting orientation*2		Unrestricted	
Impact/Vibration resistance*2 m/s ²		150/30	
Coil rated voltage DC		24 V	
Allowable voltage fluctuation V		±10% of the rated voltage	
Power consumption W	Standard	0.4	
	With power-saving circuit (Made to order)	0.1*3 [Inrush 0.4, Holding 0.1]	
Surge voltage suppressor		Diode (Varistor for non-polar type)	
Indicator light		LED	

*1 The product is IPX9K compliant (protected against high-pressure hot water). However, operation of the valve must be within the specified valve ambient temperature and fluid temperature range.

*2 Impact resistance: The value at which no malfunction occurs when tested in the axial direction and at right angles to the main valve and the armature in both energized and de-energized states, once for each condition (Values from the initial stage)

Vibration resistance: The value at which no malfunction occurs in a one-sweep test between 45 and 2000 Hz, performed in both energized and de-energized states in the axial direction and at right angles to the main valve and the armature (Values from the initial stage)

*3 For details, refer to page 37.

Valve

JSY5000-H

Sub-plate

Manifold
Exploded View

Sub-plate
Exploded View

EX430

Fittings, Plugs,
Tube Releasing Tools

Manifold
Options

Made to Order

Specific Product
Precautions

JSY5000-H Series

Manifold Specifications

Type			Lead wire	Fieldbus (IO-Link)*1
Manifold type			Plug-in connector connecting base	
SUP/EXH port type			Common SUP/EXH	
Valve stations			2 to 16 stations	
Internal wiring			Positive common Negative common (Refer to "Electrical Wiring Specifications" on page 14.)	Negative common
Port size	SUP/EXH block	1(P), 5(EA), 3(EB) port	G1/2 (Based on ISO 16030)	
	2-port type manifold block	4(A), 2(B) port	G1/4 (Based on ISO 16030)	
	5-port type manifold block	1(P), 4(A), 2(B), 5(EA), 3(EB) port	G1/4 (Based on ISO 16030)	
Enclosure			IP69K (Based on IEC/EN 60529/ISO 20653)	
External parts material			Resin parts: PA, Metal parts: Stainless steel 316, Rubber parts: EPDM	

*1 Refer to page 32 for the Fieldbus type for output (EX430 series) specifications.

Manifold Flow Rate Characteristics

Manifold block type	Port size		Flow rate characteristics			
	1, 5, 3 (P, EA, EB)	4, 2 (A, B)	1 → 4, 2 (P → A, B)		4, 2 → 5, 3(A, B → EA, EB)	
			C [dm ³ /(s·bar)]	b	C [dm ³ /(s·bar)]	b
2-port type	G1/2	G1/4	6.80	0.31	7.64	0.23
5-port type	G1/4		5.60	0.21	5.67	0.22

* The flow rate characteristics values are for an individually operated 2-position type manifold base with 5 stations.

Manifold Weight

Manifold block type (2-port/5-port type)	Weight: g*1 (n: Number of stations)
Lead wire type	227 n + 1070
Fieldbus type	227 n + 500

*1 Weight without fittings. For when a lead wire type cable is 5 m. Add the weight of the valves to be mounted from the table below to find the total weight.

Valve Weight

Valve model	Type of actuation	Weight [g]	
JSY5□03-H	2-position	Single	86
		Double	96
	3-position	Closed center	106
		Exhaust center	
		Pressure center	
	4-position	Dual 3-port	92

Response Time

Valve model	Response time [ms]*1	
	Z type	U type
JSY5103-H	40	32
JSY5203-H	19	19
JSY53/4/503-H	46	44
JSY5A/B/C03-H	38*2	29*2

*1 Based on dynamic performance test, JIS B 8419:2010 (Coil temperature: 20°C, at rated voltage)

*2 There will be an approx. 10 ms delay on the 2(B) port side due to the length of the pilot passage.

Connector Wiring Layout

For both Fieldbus and lead wire types, additional valves are sequentially assigned pins on the connector. This makes it completely unnecessary to disassemble the connector unit.

■ **Single solenoid valve is installed to all double wiring. (Double wiring specification) (Manifold specification sheet is not necessary.)**

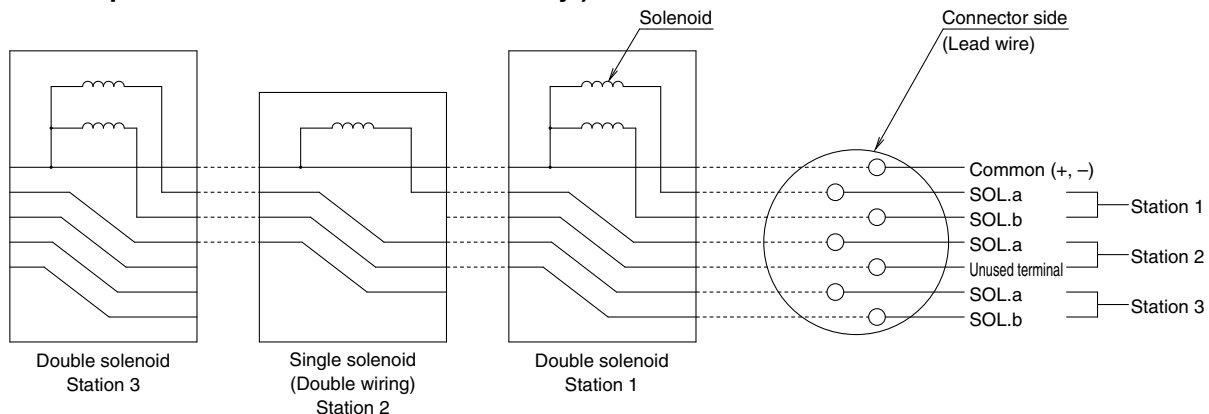

* These diagrams are for the purpose of explanation, and differ from the actual connector wiring.

JSY5000-H Series Valve Construction

Rubber Seal

2-position single

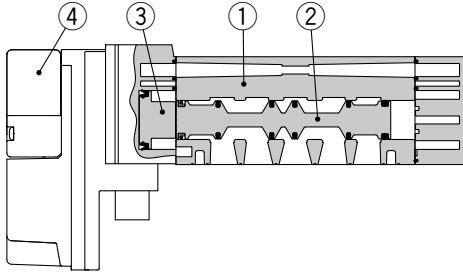

2-position single

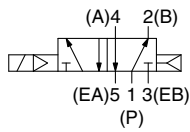

2-position double

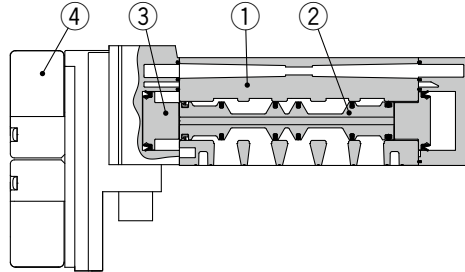

2-position double

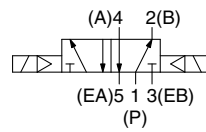

3-position closed center/exhaust center/pressure center

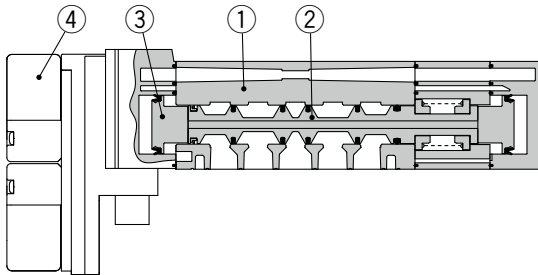

3-position closed center

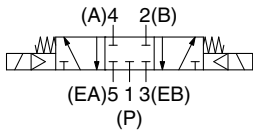

3-position exhaust center

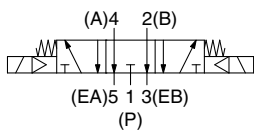

3-position pressure center

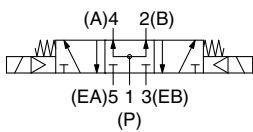

4-position dual 3-port

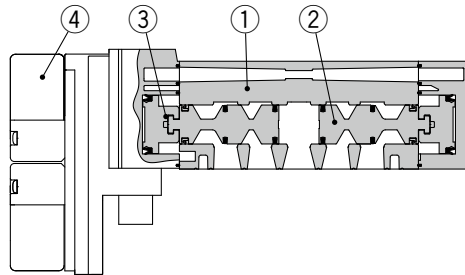

4-position dual 3-port
N.C. x 2 pcs.

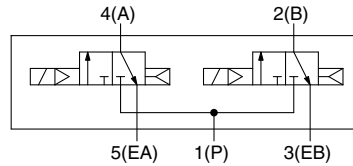

N.O. x 2 pcs.

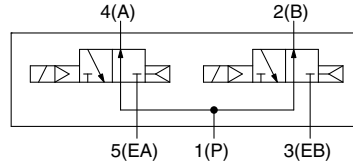

N.C./N.O. 1 pc. of each

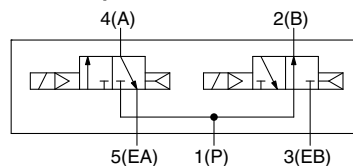

Component Parts

No.	Description	Material
1	Body	Aluminum die-casted
2	Spool valve	Aluminum/HNBR (4-position dual 3-port) Resin/HNBR
3	Piston	Resin
4	Pilot valve	—

JSY5000-H Series

Valve Replacement Parts: Pilot Valve

How to Order Pilot Valves (With a gasket and two mounting screws)

V112 - 5 A

Coil type

Nil	Standard
T	With power-saving circuit (Made to order)

Rated voltage

5	24 VDC
---	--------

⚠ Caution

1. The coil specification and voltage (including light/surge voltage suppressor) cannot be changed by changing the pilot valve.
2. When selecting the standard coil type, it is not possible to change to the power-saving circuit type.

How to replace pilot valves

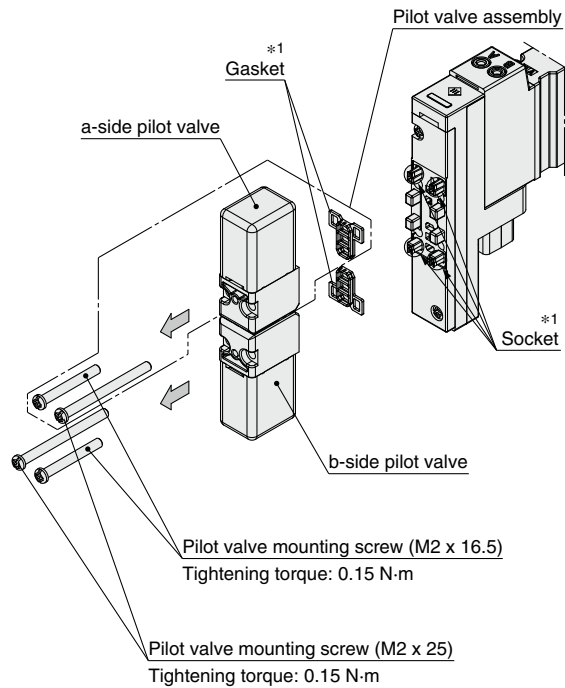

- Remove the pilot valve mounting screws.
 - Remove the pilot valve in the direction indicated by the arrow.
- *1 Ensure the gasket is mounted, and take care not to bend the socket.
- * Assemble by following the removal procedure in reverse.

Valve

JSY5000-H

Sub-plate

Manifold
Exploded View

Sub-plate
Exploded View

EX430

Fittings, Plugs,
Tube Releasing Tools

Manifold
Options

Made to Order

Specific Product
Precautions

Clean Design Manifold Valve

JSY5000-H Series

[IP69K Compliant]



This is an IP69K compliant product. The manifold and valves are ordered as a set.

How to Order Manifolds

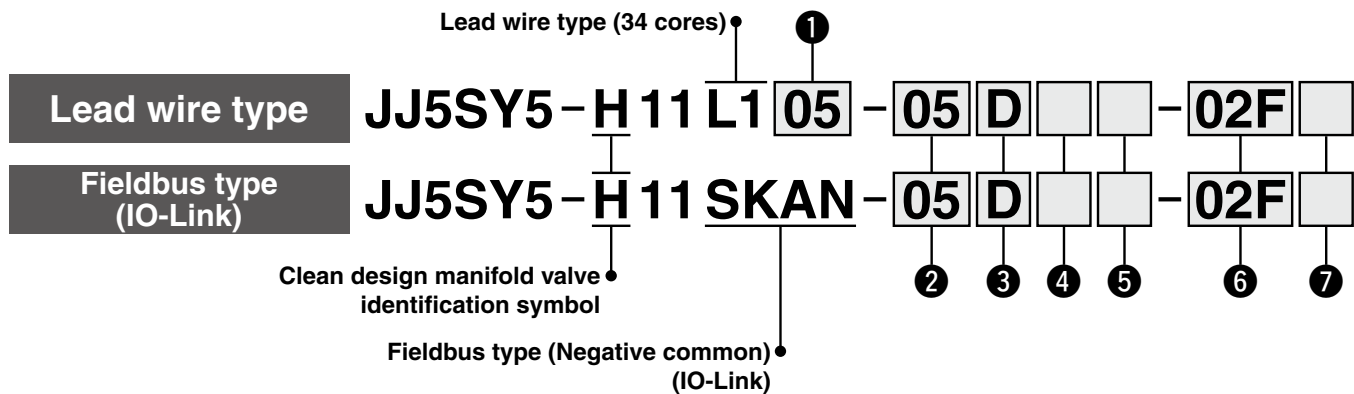

1 Lead wire length

Symbol	Length
05	5 m
10	10 m
15	15 m

2 Valve stations

Symbol	Stations	Note
02	2 stations	Double wiring*1
⋮	⋮	
16	16 stations	

*1 Valve stations number includes stations with a blanking plate, and is the total number for all 2-port and 5-port type manifold blocks.

3 SUP/EXH block 1(P), 5(EA), 3(EB) port entry

D	D side (2 to 10 stations)
B	Both sides (2 to 16 stations)

* SUP/EXH blocks with U side only is not available.

4 Pilot type

Nil	Internal pilot
R*1	External pilot

*1 External pilot port is on the D side end block.

The external pilot specification should be ordered as made to order.

5 5-port type manifold block stations

Symbol	Stations	Note
Nil	None	Specify the number of stations with 5-port type manifold blocks, so this will be equal to or less than the total number of valve stations. Specify the arrangement and blocking disk mounting position in the manifold specification sheet.
01	1 station	
⋮	⋮	
16	16 stations	

* E.g.) When the symbol is "02", 2 stations are 5-port type manifold blocks.

When the symbol is Nil or blank, all stations are of 2-port type manifold block.

* When different pressures are required, use 5-port type manifold blocks with blocking disks. Use of 5-port type manifold blocks without blocking disks can be used to provide an intermediate SUP/EXH block function.

6 Manifold block port size

[Thread piping/One-touch fitting (Metric/Inch size)]

Symbol	Fitting specifications		Manifold block port size		Note		
			2-port type	5-port type	SUP/EXH block	D side end block	
			A, B port	P, A, B, EA, EB port	P, EA, EB port	X, PE*2 port	VENT port
02F	Without fitting		G1/4 Thread piping	G1/2 Thread piping	G1/2 Thread piping	G1/8 Thread piping	M5 Thread piping
B8	Metric size Threaded One-touch fitting	Brass fitting	ø8*1	ø16	ø16	ø6	ø4*3
B10			ø10				
G8		Stainless steel fitting	ø8*1				
G10			ø10				
BN9	Inch size Threaded One-touch fitting	Brass fitting	ø5/16**1	ø1/2"	ø1/2"	ø1/4"	ø5/32**3
BN11			ø3/8"				
GN9		Stainless steel fitting	ø5/16**1				
GN11			ø3/8"				

*1 ø8 and ø5/16" One-touch fitting are common for mm and inch size.

*2 In the case of external pilot type (made to order), fittings are attached to the X and PE ports according to the above fitting type.

*3 For the VENT port ø4 and ø5/32", the same fitting is used.

7 Mounting option

Nil	None
L*1	Mounting leg (90 mm)

*1 Mounting legs are shipped together with the product.



Made to Order

(Refer to page 35 for details.)

Specifications
External pilot
Coil type: With power-saving circuit (Continuous duty type, 0.1 W)



This is an IP69K compliant product. The manifold and valves are ordered as a set.

How to Order Valves

JSY5 1 0 3 - 5 U - **H**

① ② ③ ④ ⑤ ⑥ ⑦

• Clean design manifold valve identification symbol

① Type of actuation

1	2-position	Single
2		Double
3	3-position	Closed center
4		Exhaust center
5		Pressure center
A*1	4-position dual 3-port	N.C./N.C.
B*1		N.O./N.O.
C*1		N.C./N.O.

*1 External pilot specification is not applicable for 4-position dual 3-port valves.

② Body type

0	Base mounted (For plug-in)
---	----------------------------

④ Pilot type

Nil	Internal pilot
R*1	External pilot

*1 The external pilot specification should be ordered as made to order.

③ Pilot valve exhaust method

3	Pilot valve common exhaust
---	----------------------------

⑤ Coil type

Nil	Standard
T*1	With power-saving circuit (Continuous duty type)

*1 "T" (With power-saving circuit) should be ordered as made to order.

⑥ Rated voltage

5	24 VDC
---	--------

⑦ Light/surge voltage suppressor

Symbol	With light	Surge voltage suppressor	Common specification
U	●	●	Non-polar
Z			Positive common
NZ			Negative common

* Only "Z" and "NZ" types are available with a power-saving circuit.

* For fieldbus type manifold, select non-polar (U) or negative common (NZ).



• If the valve will be continuously energized, please be sure to use the power-saving circuit (continuous duty type). Refer to Made to Order on page 35.

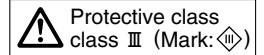

How to Order Manifold Assembly

Example (JJ5SY5-H11L105-□)

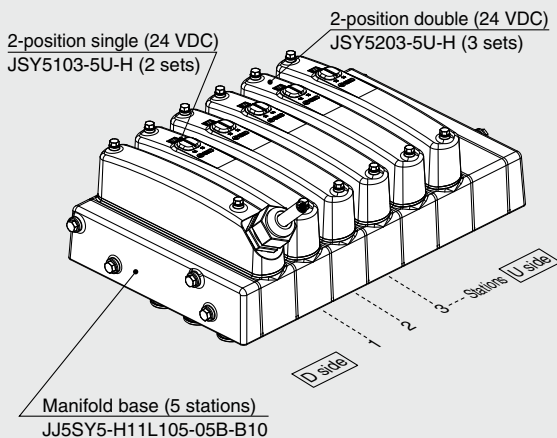

This is an IP69K compliant product. The manifold and valves are ordered as a set.

Ordering example

JJ5SY5-H11L105-05B-B10..... 1 set (Type H11 5-station manifold base part no.)
 * JSY5103-5U-H..... 2 sets (2-position single part no.)
 * JSY5203-5U-H..... 3 sets (2-position double part no.)

→ The asterisk denotes the symbol for the assembly. Prefix it to the part numbers of the valve, etc.

• For the valve arrangement, the valve closest to the D side is considered the 1st station.

• Under the manifold part number, state the valves to be mounted in order starting with the 1st station as shown in the figure above. If the arrangement becomes too complicated, specify the details on a manifold specification sheet.

Manifold Specifications

In order to assemble complex manifold patterns, or for arrangements including 5-port type manifold blocks, please use the manifold specification sheet.



Scan here to download.

JSY5000-H Series



Dimensions: Lead Wire Type

JJ5SY5-H11L1□ - Stations ^D 02F, B□
^B G□, BN□ (L)
 GN□

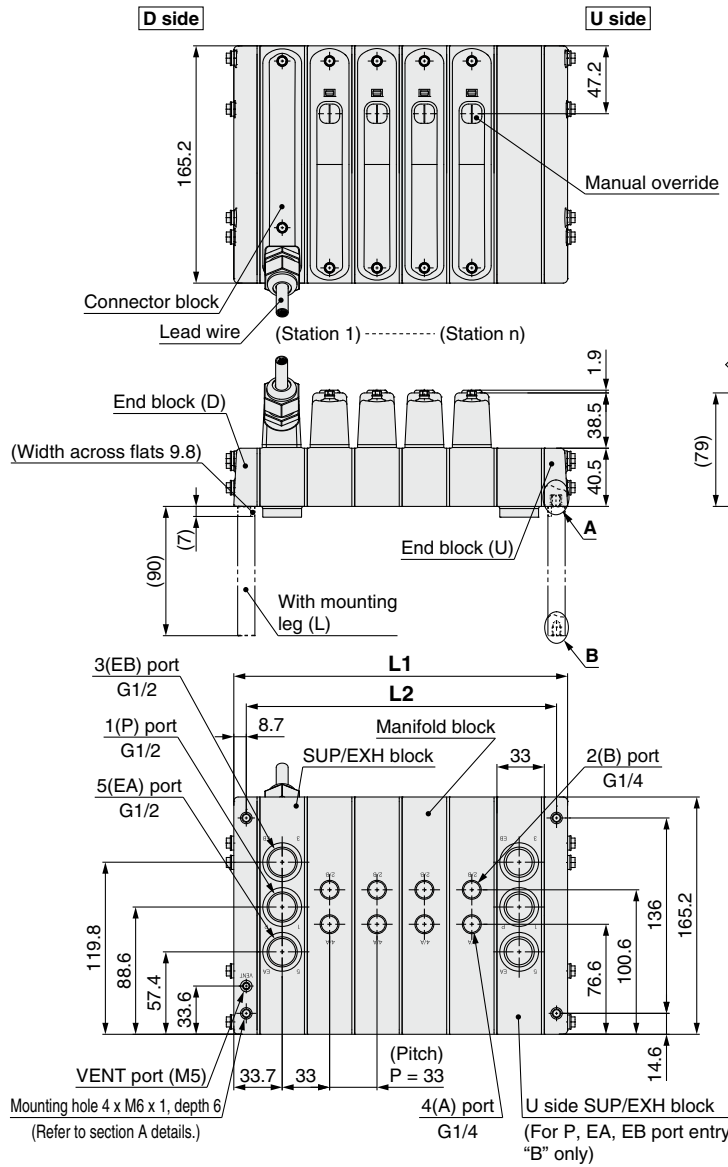

Section A details

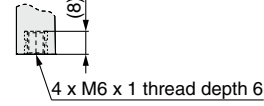

Section B details

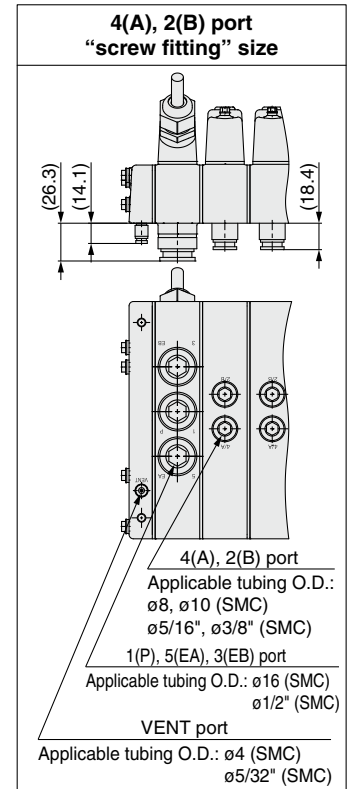
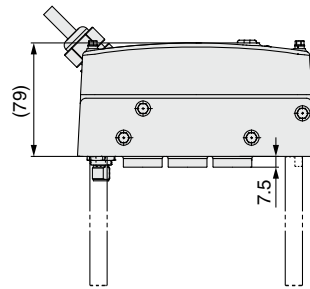
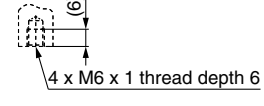

* Refer to page 17 for the panel cutout dimensions for direct mounting.

1(P), 5(EA), 3(EB) Port Entry: D Side (SUP/EXH Block)

L: Dimensions

n: Number of stations

L \ n	2	3	4	5	6	7	8	9	10
L1	133.4	166.4	199.4	232.4	265.4	298.4	331.4	364.4	397.4
L2	117	150	183	216	249	282	315	348	381

1(P), 5(EA), 3(EB) Port Entry: Both Sides (SUP/EXH Block)

L: Dimensions

n: Number of stations

L \ n	2	3	4	5	6	7	8	9	10	11	12	13	14	15	16
L1	166.4	199.4	232.4	265.4	298.4	331.4	364.4	397.4	430.4	463.4	496.4	529.4	562.4	595.4	628.4
L2	150	183	216	249	282	315	348	381	414	447	480	513	546	579	612

* These figures show the "JJ5SY5-H11L105-04B-B10."

Electrical Wiring Specifications

Lead wire

34 cores

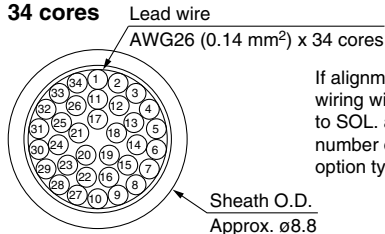

If alignment is not specified, the internal wiring will be double wiring (connected to SOL. a and SOL. b) regardless of number of stations, valve types, and option types.

Electrical characteristics

Item	Property
Conductor resistance Ω/km, 20°C	143 or less
Voltage limit V, 1 minute, AC	2000
Insulation resistance MΩ/km, 20°C	10 or more

* Cannot be used for movable wiring
The minimum bending radius of the cable is 55 mm.

Station	Lead wire no.	Polarity	Lead wire color	Printed mark (Both sides)	
				Type	Color
Station 1	SOL.a 1	(-) (+)	Orange	--	Red
	SOL.b 2	(-) (+)			Black
Station 2	SOL.a 3	(-) (+)	Light gray	--	Red
	SOL.b 4	(-) (+)			Black
Station 3	SOL.a 5	(-) (+)	White	--	Red
	SOL.b 6	(-) (+)			Black
Station 4	SOL.a 7	(-) (+)	Yellow	--	Red
	SOL.b 8	(-) (+)			Black
Station 5	SOL.a 9	(-) (+)	Pink	--	Red
	SOL.b 10	(-) (+)			Black
Station 6	SOL.a 11	(-) (+)	Orange	---	Red
	SOL.b 12	(-) (+)			Black
Station 7	SOL.a 13	(-) (+)	Light gray	--	Red
	SOL.b 14	(-) (+)			Black
Station 8	SOL.a 15	(-) (+)	White	---	Red
	SOL.b 16	(-) (+)			Black
Station 9	SOL.a 17	(-) (+)	Yellow	--	Red
	SOL.b 18	(-) (+)			Black
Station 10	SOL.a 19	(-) (+)	Pink	---	Red
	SOL.b 20	(-) (+)			Black
Station 11	SOL.a 21	(-) (+)	Orange	----	Red
	SOL.b 22	(-) (+)			Black
Station 12	SOL.a 23	(-) (+)	Light gray	----	Red
	SOL.b 24	(-) (+)			Black
Station 13	SOL.a 25	(-) (+)	White	----	Red
	SOL.b 26	(-) (+)			Black
Station 14	SOL.a 27	(-) (+)	Yellow	----	Red
	SOL.b 28	(-) (+)			Black
Station 15	SOL.a 29	(-) (+)	Pink	----	Red
	SOL.b 30	(-) (+)			Black
Station 16	SOL.a 31	(-) (+)	Orange	-----	Red
	SOL.b 32	(-) (+)			Black
	COM. 33	(+) (-)	Light gray	-----	Red
	COM. 34	(+) (-)			Black

Positive common Negative common

* For negative common specification, a valve for negative common or a valve without polarity should be used.

Valve

JSY5000-H

Sub-plate

Manifold Exploded View

Sub-plate Exploded View

EX430

Fittings, Plugs, Tube Releasing Tools

Manifold Options

Made to Order

Specific Product Precautions

JSY5000-H Series

Dimensions: Fieldbus Type (IO-Link)

JJ5SY5-H11SKAN- Stations $\begin{matrix} \text{D} & \text{02F, B} \\ \text{B} & \text{-G, BN} \\ & \text{GN} \end{matrix}$ (L)

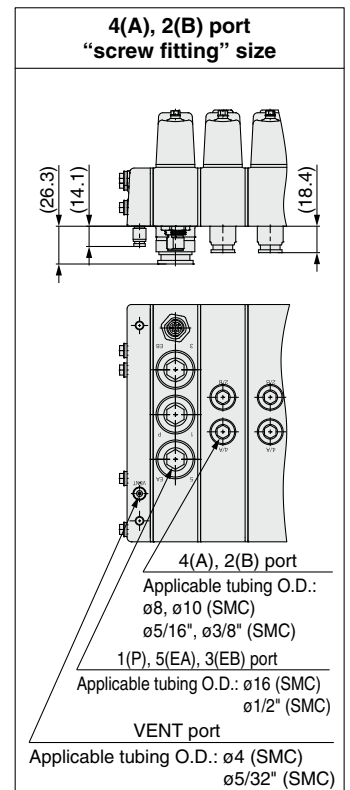
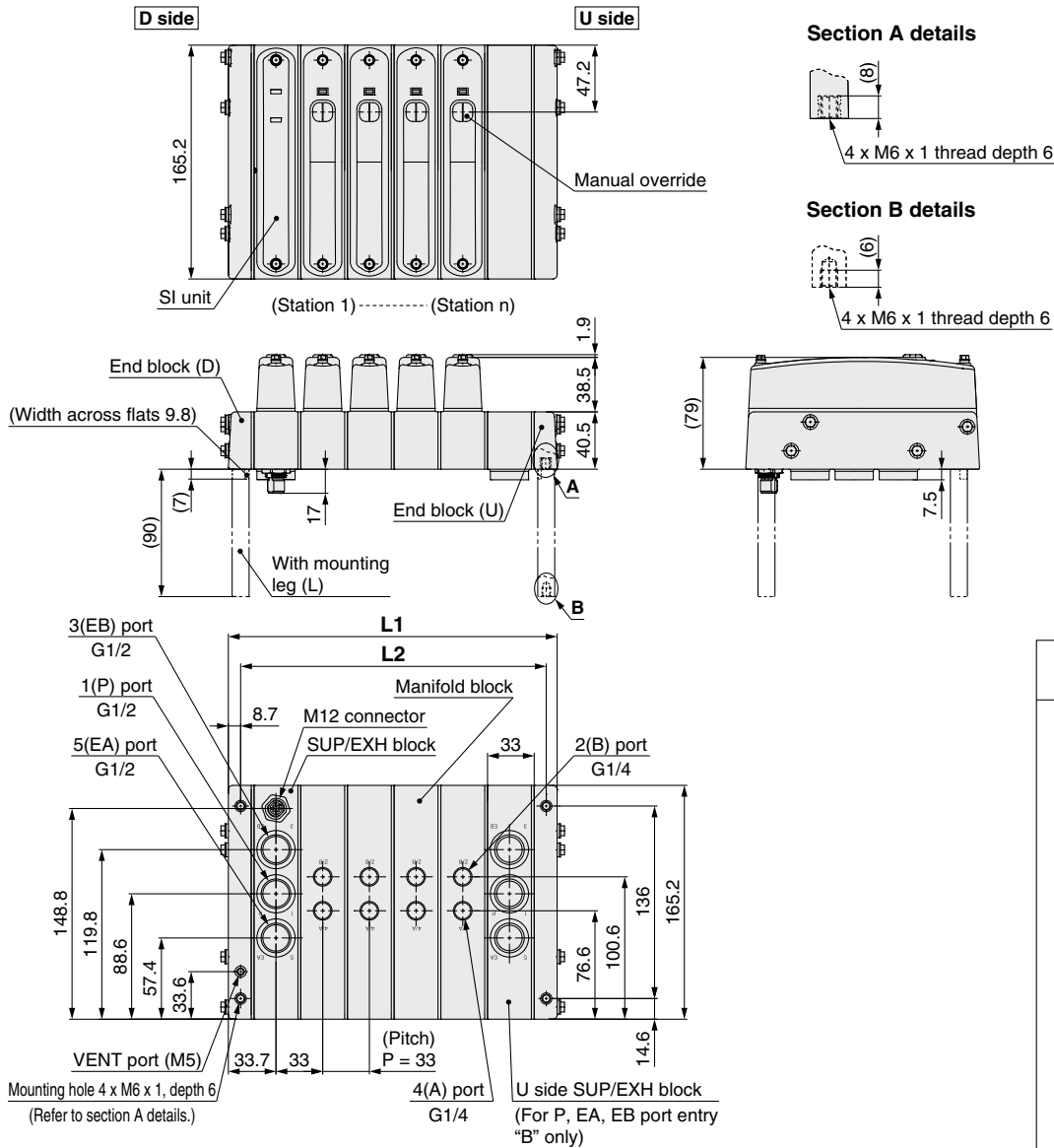
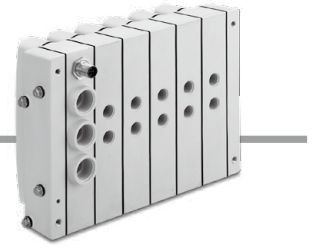

* Refer to page 17 for the panel cutout dimensions for direct mounting.

1(P), 5(EA), 3(EB) Port Entry: D Side (SUP/EXH Block)

L: Dimensions

n: Number of stations

L \ n	2	3	4	5	6	7	8	9	10
L1	133.4	166.4	199.4	232.4	265.4	298.4	331.4	364.4	397.4
L2	117	150	183	216	249	282	315	348	381

1(P), 5(EA), 3(EB) Port Entry: Both Sides (SUP/EXH Block)

L: Dimensions

n: Number of stations

L \ n	2	3	4	5	6	7	8	9	10	11	12	13	14	15	16
L1	166.4	199.4	232.4	265.4	298.4	331.4	364.4	397.4	430.4	463.4	496.4	529.4	562.4	595.4	628.4
L2	150	183	216	249	282	315	348	381	414	447	480	513	546	579	612

* These figures show the "JJ5SY5-H11SKAN-04B-B10."

Dimensions: 5-Port Type Manifold Block [Common to Lead Wire Type/Fieldbus Type (IO-Link)]

JJ5SY5-H11^{L1}SKAN - Valve stations ^D(R) 5-port type manifold block stations - 02F, B[□]
 - G[□], BN[□] (L)
 GN[□]

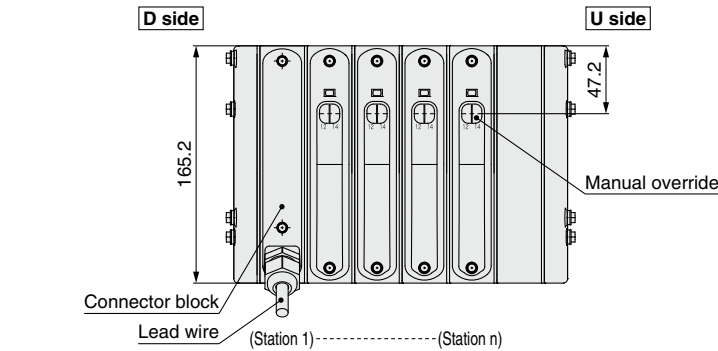

Section A details



Section B details

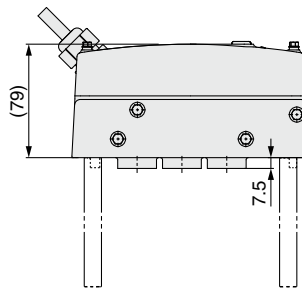
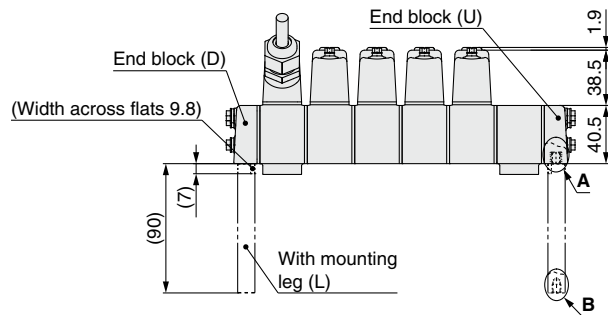
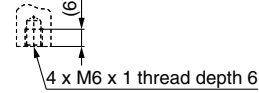

Section C details

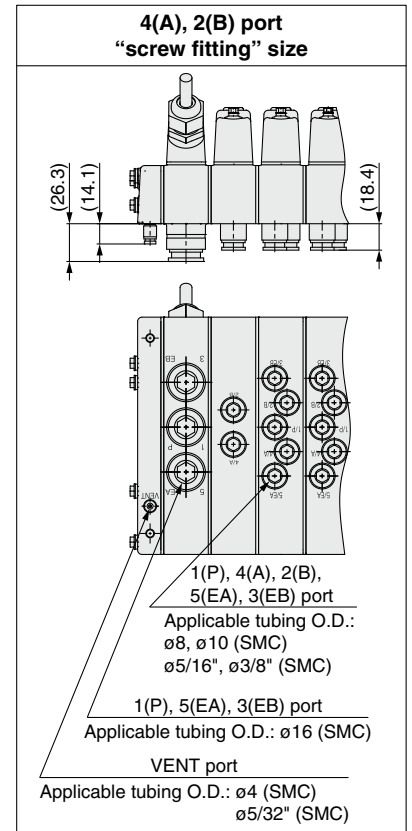
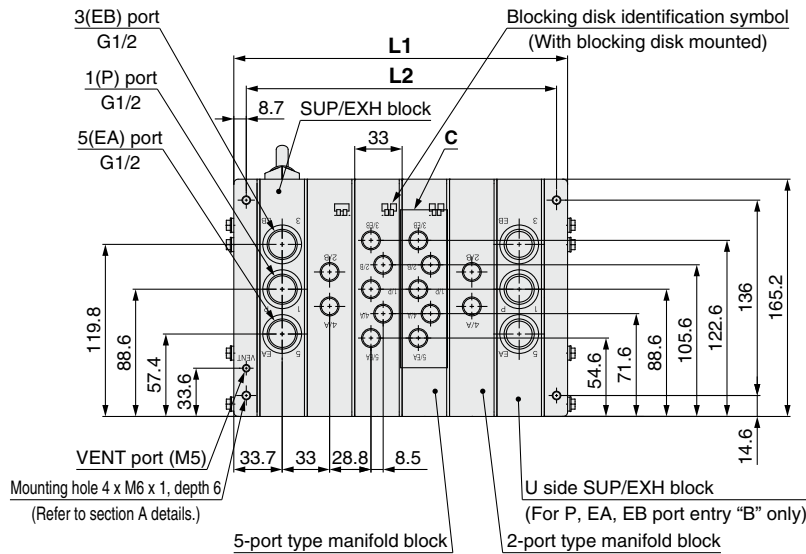
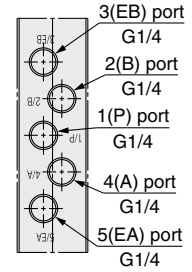

* These figures show the "JJ5SY5-H11L105-04B02-02F"
 * Refer to page 17 for the panel cutout dimensions for direct mounting.

1(P), 5(EA), 3(EB) Port Entry: D Side (SUP/EXH Block)

L: Dimensions n: Number of stations

L \ n	2	3	4	5	6	7	8	9	10
L1	133.4	166.4	199.4	232.4	265.4	298.4	331.4	364.4	397.4
L2	117	150	183	216	249	282	315	348	381

1(P), 5(EA), 3(EB) Port Entry: Both Sides (SUP/EXH Block)

L: Dimensions n: Number of stations

L \ n	2	3	4	5	6	7	8	9	10	11	12	13	14	15	16
L1	166.4	199.4	232.4	265.4	298.4	331.4	364.4	397.4	430.4	463.4	496.4	529.4	562.4	595.4	628.4
L2	150	183	216	249	282	315	348	381	414	447	480	513	546	579	612

JSY5000-H Series

Dimensions: Panel Cutout Dimensions

JJ5SY5-H11L1□ - Stations $\begin{matrix} D \\ B \end{matrix}$ (R)- $\begin{matrix} 02F, B \\ G, BN \\ GN \end{matrix}$ (L)

JJ5SY5-H11SKAN- Stations $\begin{matrix} D \\ B \end{matrix}$ (R)- $\begin{matrix} 02F, B \\ G, BN \\ GN \end{matrix}$ (L)

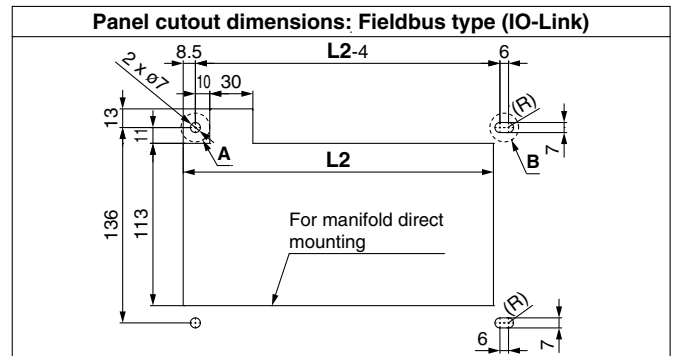
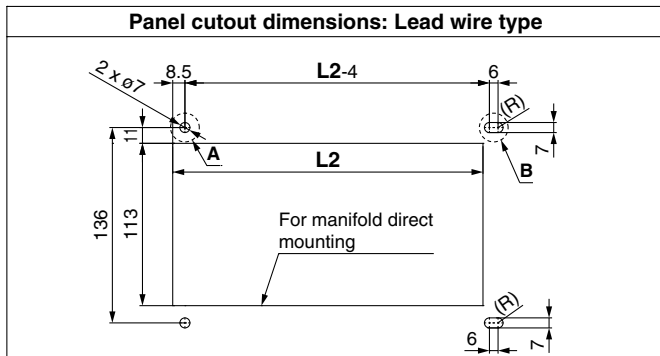
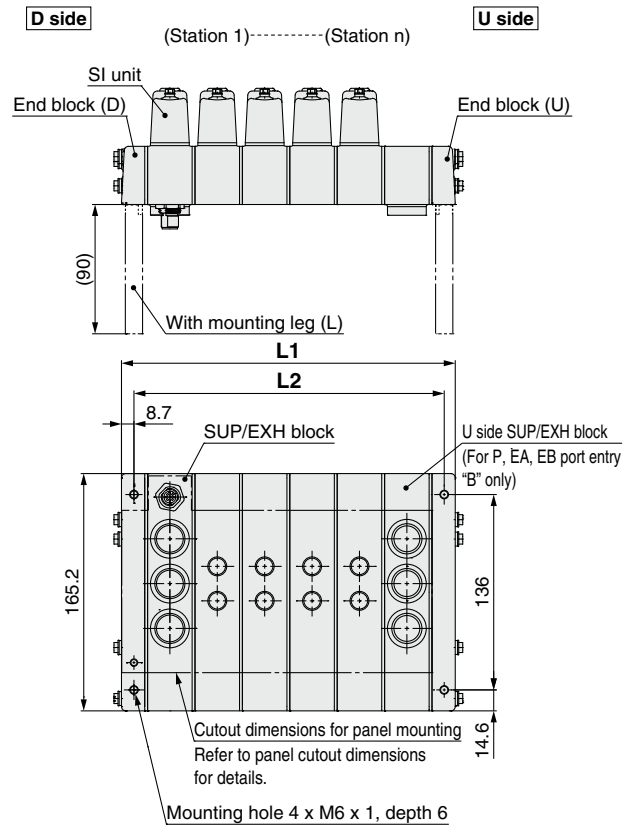
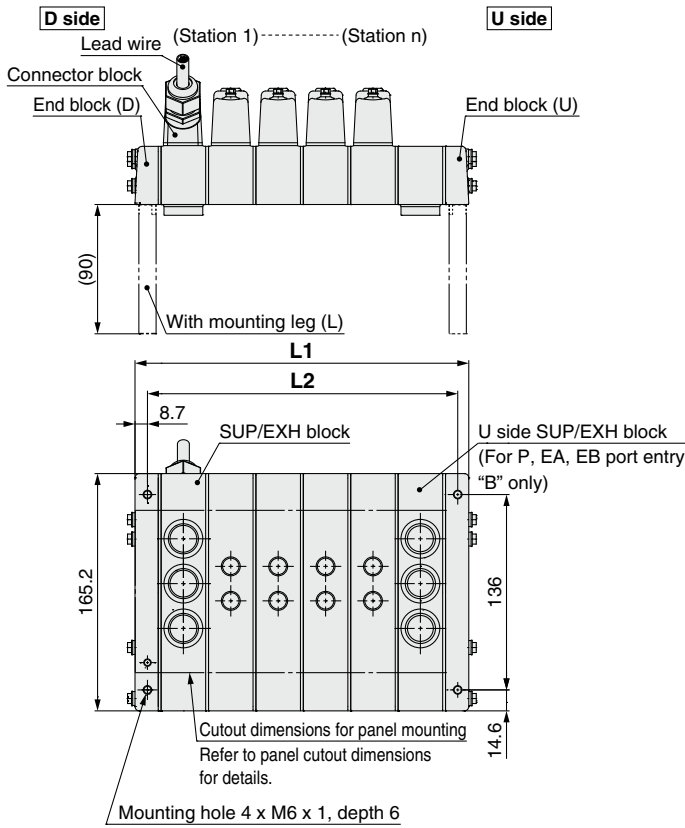

* When mounting with the mounting leg (L), only the leg mounting holes (round/elongated) are machined.

* When mounting with the mounting leg (L), only the leg mounting holes (round/elongated) are machined.

Section A mounting hole details

Section B mounting hole details

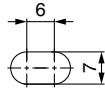
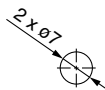

* Tolerance: ± 0.2

1(P), 5(EA), 3(EB) Port Entry: D Side (SUP/EXH Block)

L: Dimensions

n: Number of stations

L \ n	2	3	4	5	6	7	8	9	10
L1	133.4	166.4	199.4	232.4	265.4	298.4	331.4	364.4	397.4
L2	117	150	183	216	249	282	315	348	381

1(P), 5(EA), 3(EB) Port Entry: Both Sides (SUP/EXH Block)

L: Dimensions

n: Number of stations

L \ n	2	3	4	5	6	7	8	9	10	11	12	13	14	15	16
L1	166.4	199.4	232.4	265.4	298.4	331.4	364.4	397.4	430.4	463.4	496.4	529.4	562.4	595.4	628.4
L2	150	183	216	249	282	315	348	381	414	447	480	513	546	579	612

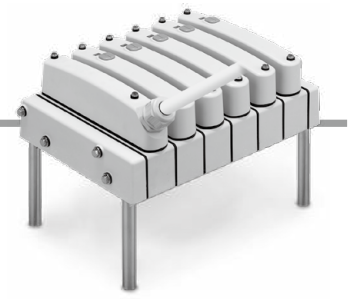

Dimensions: External Pilot (Made to Order)

JJ5SY5-H11 L1□ SKAN - Stations D_BR - 02F, B□
G□, BN□ (L)
GN□

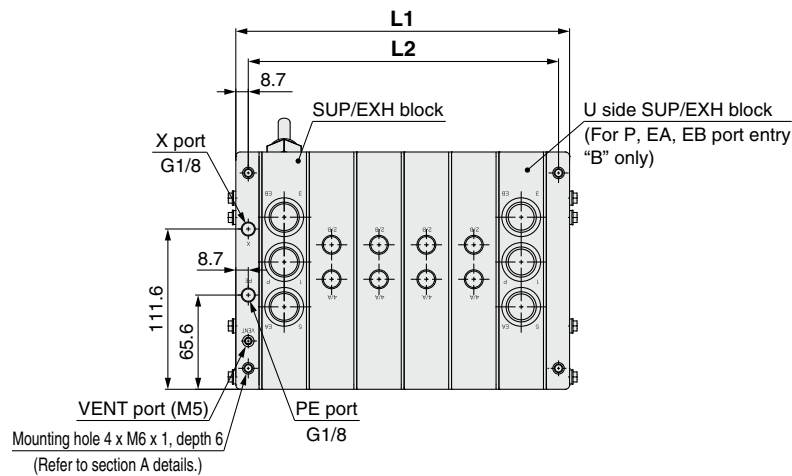
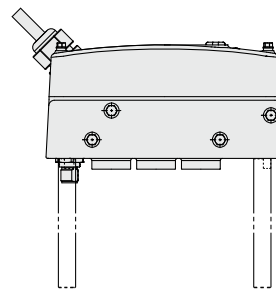
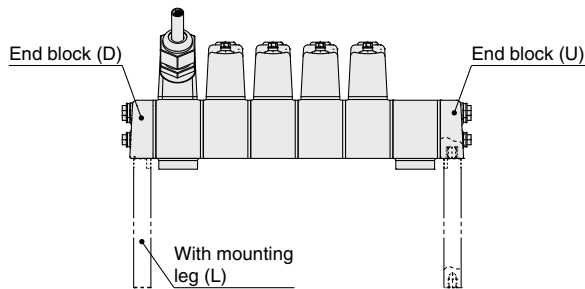
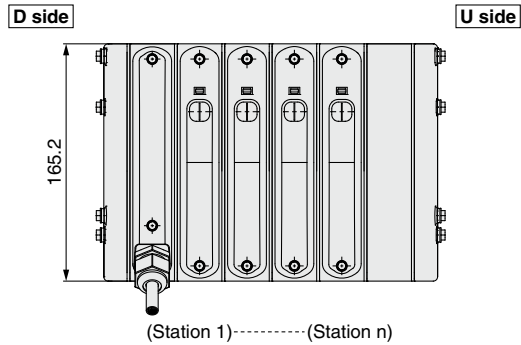

* Refer to page 17 for panel cutout dimensions.

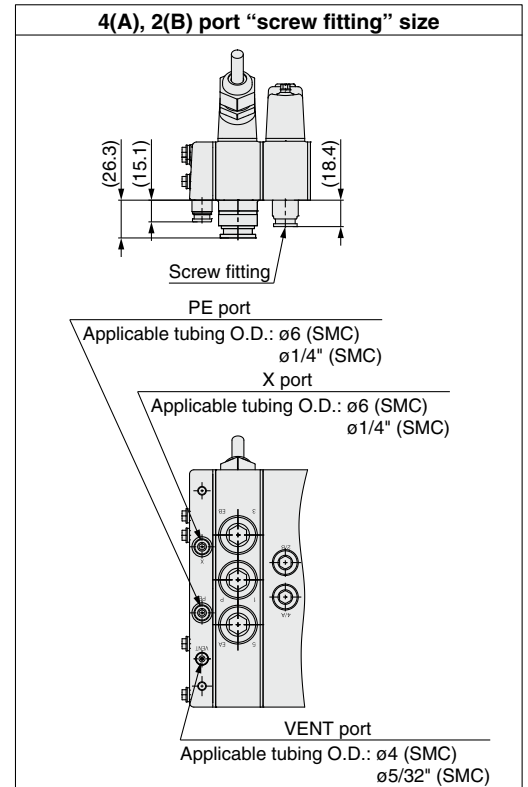

* These figures show the "JJ5SY5-H11L105-04BR-B10."

1(P), 5(EA), 3(EB) Port Entry: D Side (SUP/EXH Block)

L: Dimensions n: Number of stations

L \ n	2	3	4	5	6	7	8	9	10
L1	133.4	166.4	199.4	232.4	265.4	298.4	331.4	364.4	397.4
L2	117	150	183	216	249	282	315	348	381

1(P), 5(EA), 3(EB) Port Entry: Both Sides (SUP/EXH Block)

L: Dimensions n: Number of stations

L \ n	2	3	4	5	6	7	8	9	10	11	12	13	14	15	16
L1	166.4	199.4	232.4	265.4	298.4	331.4	364.4	397.4	430.4	463.4	496.4	529.4	562.4	595.4	628.4
L2	150	183	216	249	282	315	348	381	414	447	480	513	546	579	612

Sub-plate (Single Unit) [IP69K Compliant]



Sub-plate Specifications

Type	Plug-in single unit type with M12 plug connector	
SUP/EXH port type	1(P), 5, 3(EA, EB) individual port	
Internal wiring	Positive common Negative common (Refer to the pin arrangement on page 20.)	
Port size	1(P), 5/3(EA/EB)	G1/4 (Based on ISO 16030)
	4(A), 2(B)	
Enclosure	IP69K (Based on IEC/EN 60529/ISO 20653)	
External parts material	Resin parts: PA, Metal parts: Stainless steel 316, Rubber parts: EPDM	

Sub-plate Flow Rate Characteristics/Weight

Port size		Flow rate characteristics				Weight: g* ¹
1, 5, 3 (P, EA, EB)	4, 2 (A, B)	1 → 4, 2 (P → A, B)		4, 2 → 5, 3 (A, B → EA, EB)		
		C [dm ³ /(s·bar)]	b	C [dm ³ /(s·bar)]	b	
G1/4	G1/4	6.75	0.31	6.53	0.22	180

*1 Weight without fittings, valve, and M12 cable. Valve weight can be added from page 7.

How to Order Sub-plates (With Valve/Valve Cover)

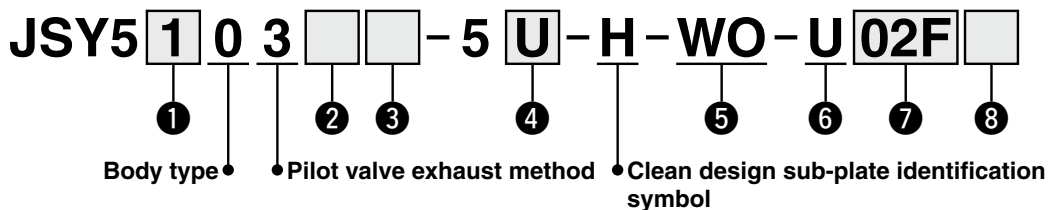

1 Type of actuation

1	2-position	Single
2		Double
3	3-position	Closed center
4		Exhaust center
5		Pressure center
A*1	4-position dual 3-port	N.C./N.C.
B*1		N.O./N.O.
C*1		N.C./N.O.

*1 External pilot specification is not applicable for 4-position dual 3-port valves.

4 Light/surge voltage suppressor

Symbol	With light	Surge voltage suppressor	Common specification
U	•	•	Non-polar
Z	•	•	Positive common
NZ	•	•	Negative common

* Only "Z" and "NZ" types are available with a power-saving circuit.

7 1(P), 4(A), 2(B), 5(EA), 3(EB) port size [Thread piping/One-touch fitting (Metric/Inch size)]

Symbol	Fitting specifications		P, A, B, EA, EB port One-touch fitting size	Note	
				X, PE*2 port	VENT port
02F	Without fitting		G1/4 Thread piping	M5 Thread piping	M5 Thread piping
B8	Metric size Threaded One-touch fitting	Brass fitting	ø8*1	ø4	ø4*3
B10			ø10		
G8		Stainless steel fitting	ø8*1		
G10	ø10				
BN9	Inch size Threaded One-touch fitting	Brass fitting	ø5/16**1	ø5/32"	ø5/32**3
BN11			ø3/8"		
GN9		Stainless steel fitting	ø5/16**1		
GN11			ø3/8"		

*1 For B8/G8 (ø8) and BN9/GN9 (ø5/16"), the same fitting is used for them.

*2 In the case of external pilot type, fittings are attached to the X and PE ports according to the above fitting type.

*3 For X, PE port and VENT port of ø4 and ø5/32", the same fitting is used.

Recommended M12 Connector Cables (IP69K and FDA-compliant products)



Cable length	PHOENIX CONTACT Product no.	PHOENIX CONTACT Order no.	Note
1.5 m	SAC-4P-1,5-600/M12FS HD	1403956	Produced upon receipt of order
3 m	SAC-4P-3,0-600/M12FS HD	1403957	
5 m	SAC-4P-5,0-600/M12FS HD	1403958	
10 m	SAC-4P-10,0-600/M12FS HD	1403959	

Caution Order the Phoenix Contact products from the manufacturer or the distributors.

2 Pilot type

Nil	Internal pilot
R*1	External pilot

*1 The external pilot specification should be ordered as made to order.

3 Coil type

Nil	Standard
T*1	With power-saving circuit (Continuous duty type)

*1 "T" (With power saving circuit) should be ordered as made to order.

5 Wiring specification

WO	Without M12 connector cable
-----------	-----------------------------

6 Port location

U	Bottom ported
----------	---------------

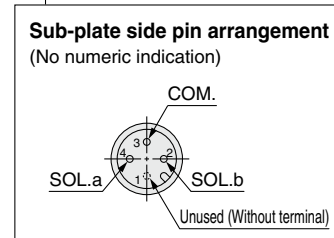
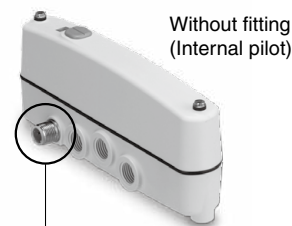

* Plug connector type

8 Mounting option

Nil	None
L*1	Mounting leg (90 mm)

*1 Mounting legs are shipped together with the product.

Valve

JSY5000-H

Sub-plate

Manifold Exploded View

Sub-plate Exploded View

EX430

Fittings, Plugs, Tube Releasing Tools

Manifold Options

Made to Order

Specific Product Precautions

JSY5000-H Series

Dimensions: Sub-plate

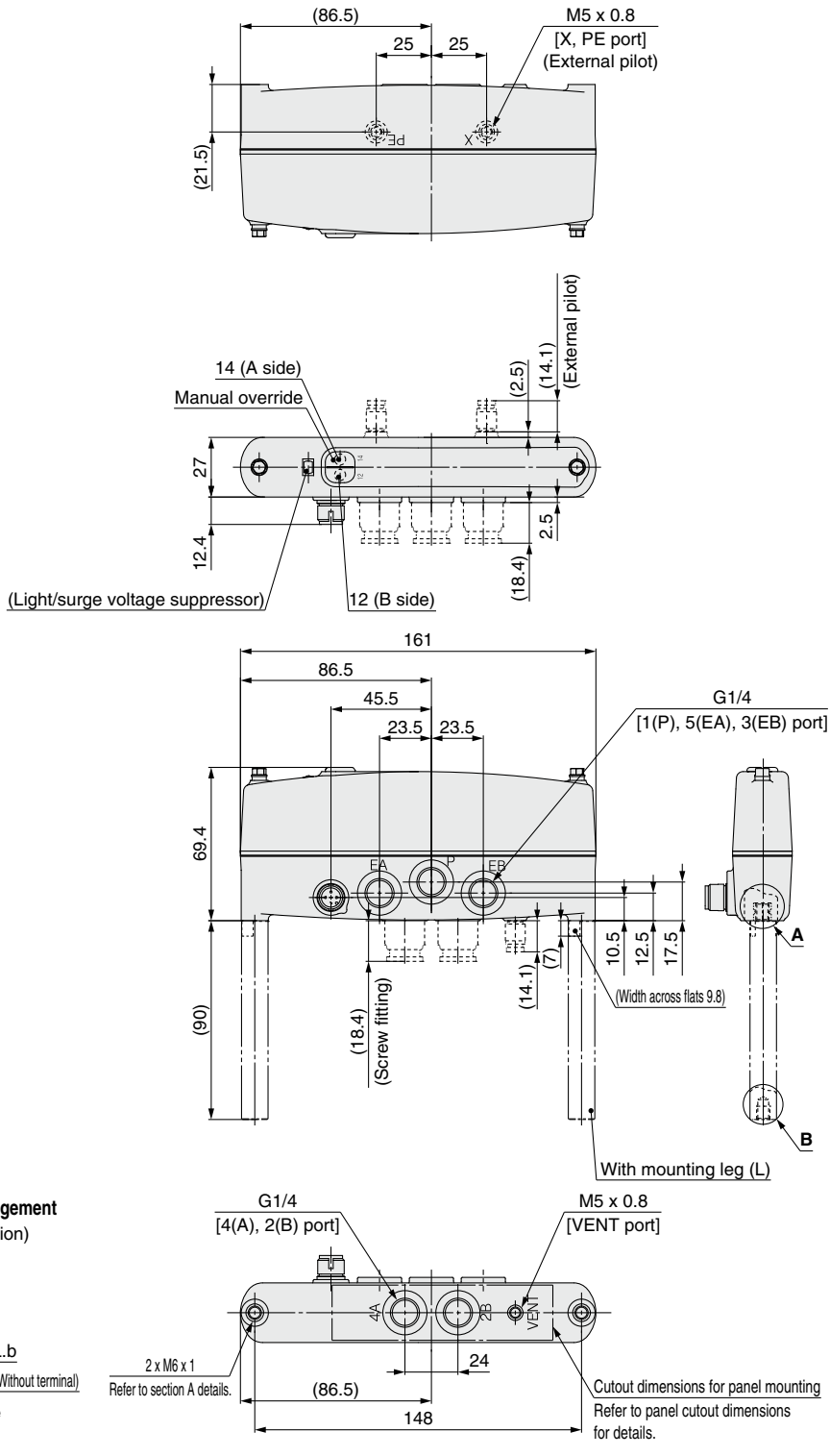

Sub-plate side pin arrangement (No numeric indication)

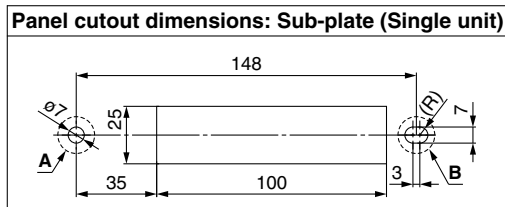
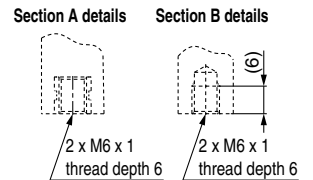
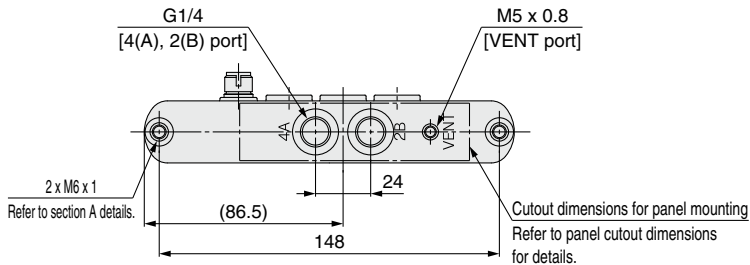
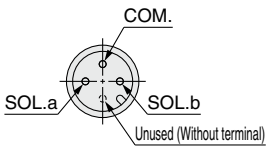

Section A mounting hole details Section B mounting hole details

* Tolerance: ±0.2

Specific Product
Precautions

Made to Order

Manifold
Options

Fittings, Plugs,
Tube Releasing Tools

EX430

Sub-plate
Exploded View

Manifold
Exploded View

Sub-plate

JSY5000-H

Valve

JSY5000-H Series Manifold Exploded View

Wiring

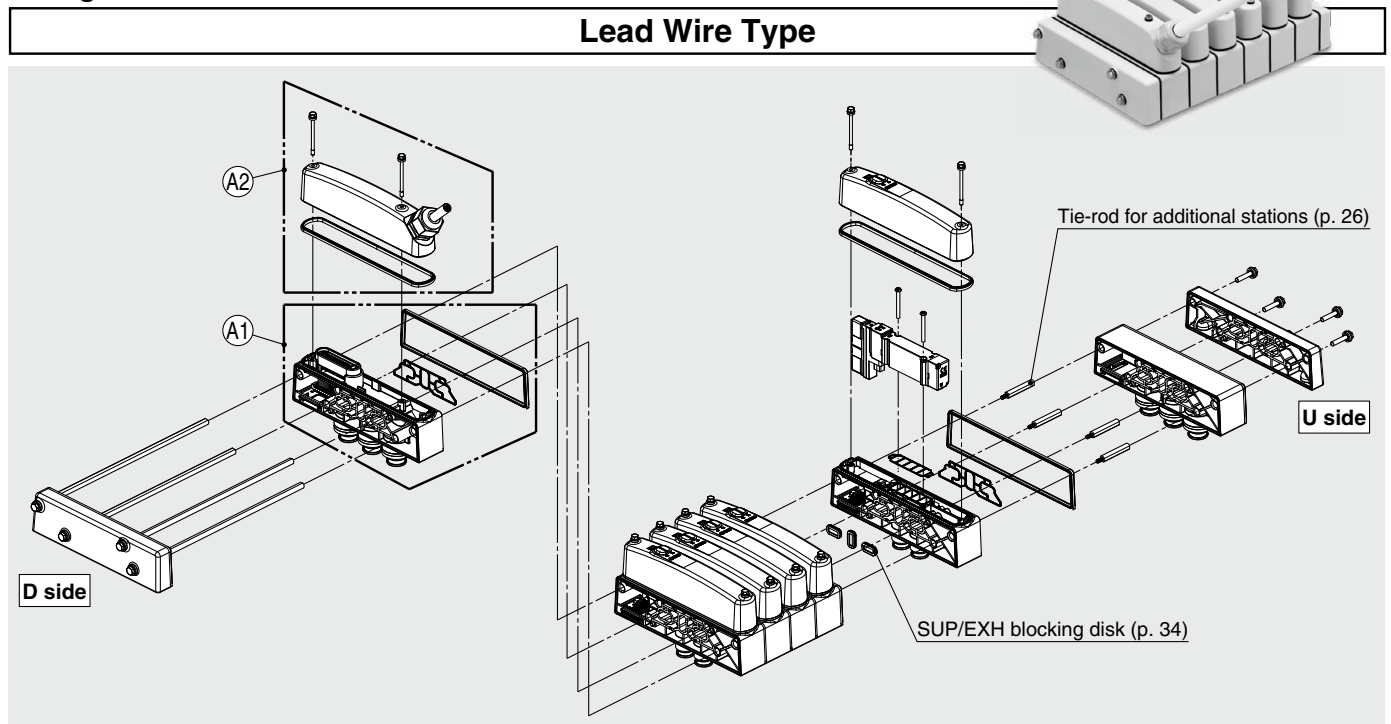

Manifold Parts Nos.

① SUP/EXH block assembly

JSY51M - 101P - 1 A - 04F

Lead wire type

1(P), 5(EA), 3(EB) port size

[Thread piping/One-touch fitting (Metric/Inch size)]

Symbol	Fitting specifications		P, EA, EB port One-touch fitting size
04F	Without fitting		G1/2, Thread piping
B12	Metric size Threaded	Brass fitting	ø12
B16		Stainless steel fitting	ø16
G12	One-touch fitting	Brass fitting	ø12
G16		Stainless steel fitting	ø16
BN11	Inch size Threaded	Brass fitting	ø3/8"
GN11		Stainless steel fitting	ø1/2"
GN13	One-touch fitting	Stainless steel fitting	ø3/8"
			ø1/2"

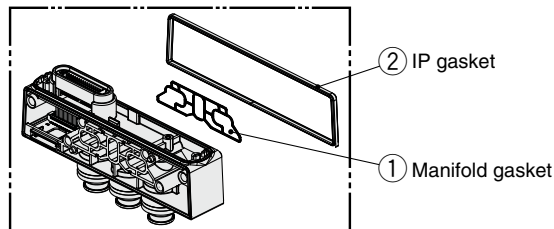

Gaskets are mounted.

(When mounting the manifold, make sure that the gasket is not misaligned, damaged, forgotten to be attached, and that there are not foreign objects.)

SUP/EXH block assembly accessories and the number of accessories

Accessories	Quantity (Mounted)
① Manifold gasket	1 pc.
② IP gasket	1 pc.

* Refer to page 26 for ordering single unit.

② Lead wire connector block assembly

JSY51M - 114P - 1A - 1 - 05

Lead wire length

05	5 m
10	10 m
15	15 m

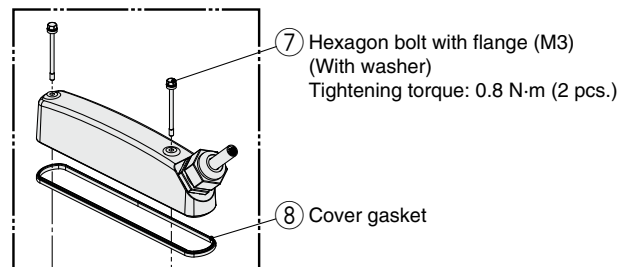

Hexagon bolts with flange and the gasket are mounted.
(When mounting the manifold, make sure that the gasket is not misaligned, damaged, forgotten to be attached, and that there are not foreign objects.)

Lead wire connector block assembly accessories and the number of accessories

Accessories	Quantity (Mounted)
⑦ Hexagon bolt with flange (M3) (With washer)	2 pcs.
⑧ Cover gasket	1 pc.

* Refer to page 26 for ordering single unit.

Wiring

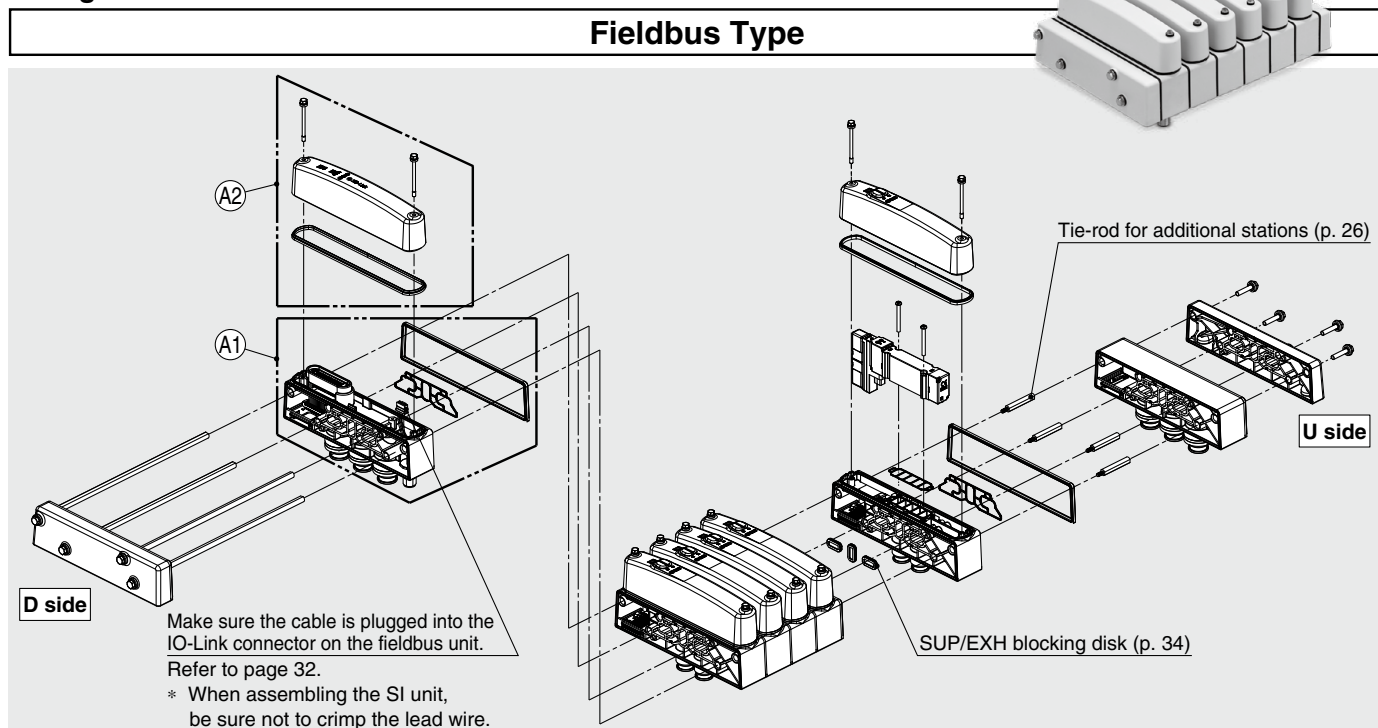

Manifold Parts Nos.

① SUP/EXH block assembly

JSY51M - 101P - 2 A - 04F
 Fieldbus type • 1(P), 5(EA), 3(EB) port size •
 [Thread piping/One-touch fitting (Metric/Inch size)]

Symbol	Fitting specifications		P, EA, EB port One-touch fitting size
04F	Without fitting		G1/2, Thread piping
B12	Metric size Threaded	Brass fitting	ø12
B16		Stainless steel fitting	ø16
G12	One-touch fitting	Brass fitting	ø12
G16		Stainless steel fitting	ø16
BN11	Inch size Threaded	Brass fitting	ø3/8"
BN13		Stainless steel fitting	ø1/2"
GN11	One-touch fitting	Brass fitting	ø3/8"
GN13		Stainless steel fitting	ø1/2"

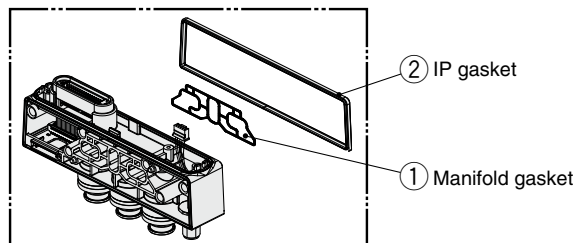

Gaskets are mounted.
 (When mounting the manifold, make sure that the gasket is not misaligned, damaged, forgotten to be attached, and that there are not foreign objects.)

SUP/EXH block assembly accessories and the number of accessories

Accessories	Quantity (Mounted)
① Manifold gasket	1 pc.
② IP gasket	1 pc.

* Refer to page 26 for ordering single unit.

② Fieldbus system

EX430 - S IL1 * Refer to page 32 for details.

• Communication protocol

Symbol	Protocol	Output polarity	Communication connector	Manifold symbol
IL1	IO-Link	Source/PNP (Negative common)	M12*1	SKAN

*1 The M12 connector is located on the SUP/EXH block on the D side.

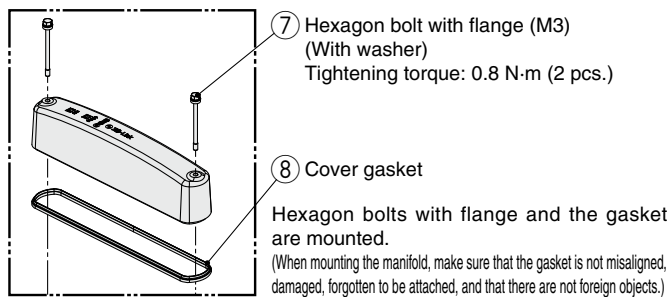

SI unit accessories and the number of accessories

Accessories	Quantity (Mounted)
⑦ Hexagon bolt with flange (M3) (With washer)	2 pcs.
⑧ Cover gasket	1 pc.

* Refer to page 26 for ordering single unit.

Communication cable (IO-Link compatible, With M12 connector on both sides (plug/socket))

[Recommended IP69K and FDA-compliant products]

Cable length	PHOENIX CONTACT Product no.	PHOENIX CONTACT Order no.	Note
1.5 m	SAC-5P-M12MS/1,5-600/M12FS HD	1404065	Produced upon receipt of order
3 m	SAC-5P-M12MS/3,0-600/M12FS HD	1404066	
5 m	SAC-5P-M12MS/5,0-600/M12FS HD	1413144	
10 m	SAC-5P-M12MS/10,0-600/M12FS HD	1413143	

⚠ Caution Order the Phoenix Contact products from the manufacturer or the distributors.

Manifold Exploded View (Common Parts)

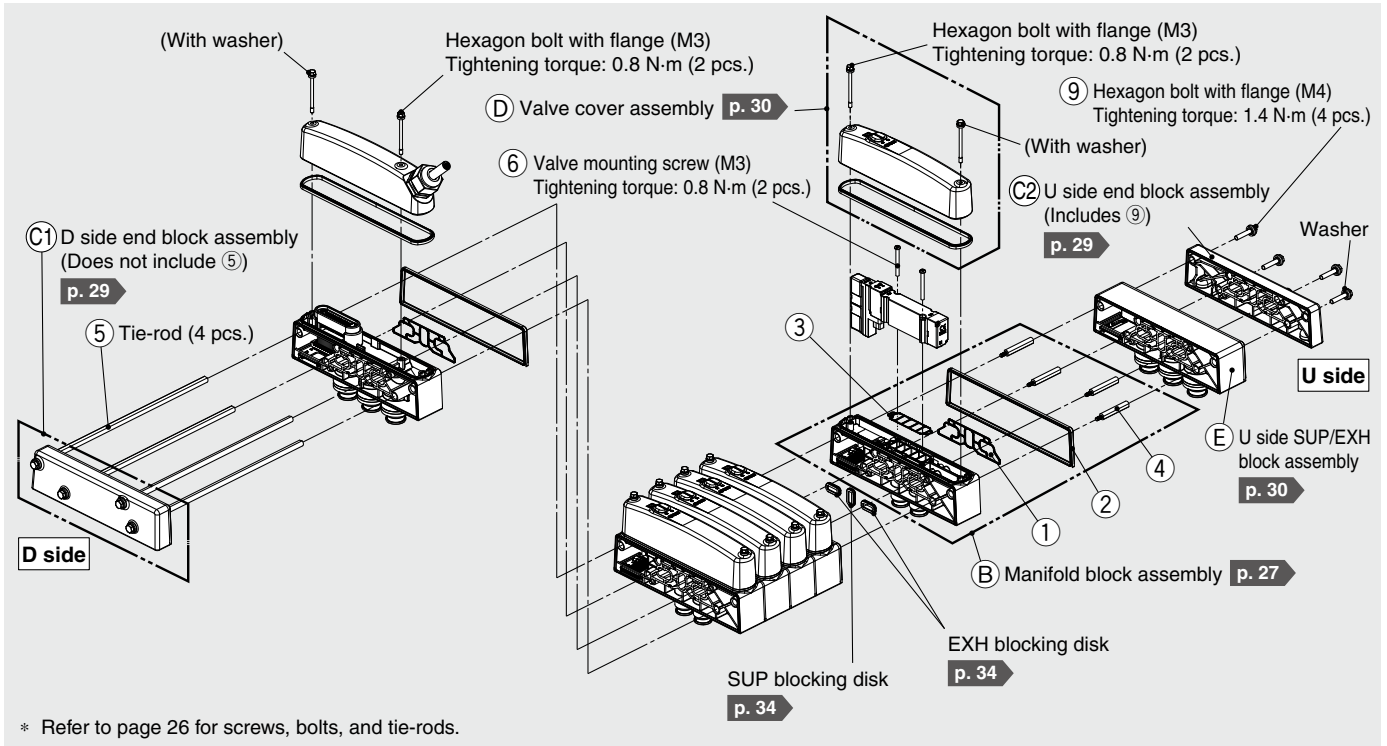

How to Increase Manifolds

- 1 Loosen the hexagon bolt with flange ⑨ on the U side, and remove the ② U side end block assembly.
(For SUP/EXH from both sides, remove the ⑤ U side SUP/EXH block assembly.)
* Do not loosen the hexagon bolt with flange of D side as the tie-rod is fixed to the ① D side end block assembly.
- 2 Screw in ④ tie-rods for additional stations to the ⑤ tie-rod of the manifold.
(Screw them in until there is no gap between the tie-rods.)
- 3 Connect ③ manifold block assembly and ② U side end block assembly that need to be added, and tighten ⑨ hexagon bolt with flange on the U side. For SUP/EXH from both sides, also connect the ⑤ U side SUP/EXH block. (4 places, more than 2 turns)
(Make sure that the washers are assembled to the hexagon bolt with flange.)
(When mounting the manifold, make sure that the gasket is not misaligned, damaged, forgotten to be attached, and that there are not foreign objects.)

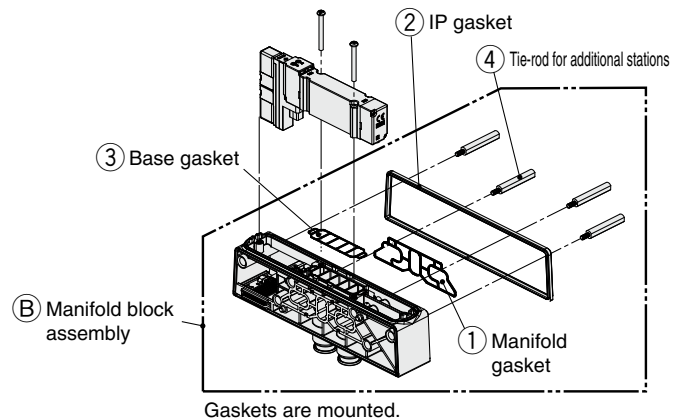

Manifold block assembly

No.	Description	Quantity
①	Manifold gasket	1 pc. (Mounted)
②	IP gasket	1 pc. (Mounted)
③	Base gasket	1 pc. (Mounted)
④	Tie-rod for additional stations	4 pcs. (Included)

* Refer to page 26 for ordering single unit.

⚠ Caution

1. Be sure to shut off the power and air supplies before disassembly.
Furthermore, since air may remain inside the actuator, piping, and manifold, confirm that the air is completely exhausted before performing any work.
2. When disassembly and assembly are performed, air leakage may result if the tightening of the hexagon bolt with flange is inadequate.
3. Rubber parts are attached to the metal parts of the washer. If they are misaligned or dislodged, return them to their normal position.

Manifold Parts Nos.

No.	Description	Part no.	Note
①	Manifold block assembly	Manifold gasket	JSY51M-109P-1A For 10 valves (10 pcs.)
②		IP gasket	JSY51M-109P-3A For 10 valves (10 pcs.)
③		Base gasket	JSY51M-9P-1A For 10 valves (10 pcs.)
④		Tie-rod for additional stations	JSY51M-49P-2A For 1 station (4 pcs.)
⑤	Tie-rod	JSY51M-49P-1-□A	Refer to the table below for the number of □. 4 tie-rods per manifold
⑥	Valve mounting screw	JSY51V-23-1A (M3 x 29)	For 10 valves (20 pcs.)
⑦	Hexagon bolt with flange (M3) (With washer) (For connector block/SI unit cover/valve cover)	JSY51M-123P-1A (M3 x 40)	For 5 valves (10 pcs.)
⑧	Cover gasket (For connector block/SI unit cover/valve cover)	JSY51M-109P-2A	For 10 valves (10 pcs.)
⑨	Hexagon bolt with flange (M4) (With washer) (For end block)	JSY51M-123P-2A (M4 x 24)	8 bolts per manifold

Tie-rod Order Nos. (1 set includes 4 pcs.)

Manifold stations	Tie-rod part no.	
	SUP/EXH block assembly: D side	SUP/EXH block assembly: B (Both sides)
2	JSY51M-49P-1-2A	JSY51M-49P-1-3A
3	JSY51M-49P-1-3A	JSY51M-49P-1-4A
4	JSY51M-49P-1-4A	JSY51M-49P-1-5A
5	JSY51M-49P-1-5A	JSY51M-49P-1-6A
6	JSY51M-49P-1-6A	JSY51M-49P-1-7A
7	JSY51M-49P-1-7A	JSY51M-49P-1-8A
8	JSY51M-49P-1-8A	JSY51M-49P-1-9A
9	JSY51M-49P-1-9A	JSY51M-49P-1-10A
10	JSY51M-49P-1-10A	JSY51M-49P-1-11A
11	For a manifold of 11 or more stations, only the SUP/EXH block assembly: B (Both sides) can be selected.	JSY51M-49P-1-12A
12		JSY51M-49P-1-13A
13		JSY51M-49P-1-14A
14		JSY51M-49P-1-15A
15		JSY51M-49P-1-16A
16		JSY51M-49P-1-17A

■ Mounting leg (4 pcs./set): For manifold

JSY51M-115P-1A



Mounting leg (M6)
Tightening torque: 4.9 N·m

* When the manifold part number (L) is ordered, the mounting legs are not assembled but included in the same package.

Valve

JSY5000-H

Sub-plate

Manifold Exploded View

Sub-plate Exploded View

EX430

Fittings, Plugs, Tube Releasing Tools

Manifold Options

Made to Order

Specific Product Precautions

JSY5000-H Series

Manifold Parts Nos.

Ⓑ Manifold block assembly

JSY51M - 102P - 1 DA - 02F

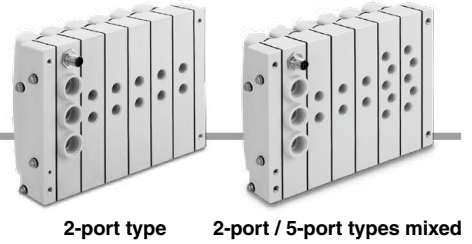

Piping specification

1	2-port type (4(A), 2(B) port)
2	5-port type (1(P), 4(A), 2(B), 5(EA), 3(EB) port)

Double wiring

With blocking disk (Laser marking)

Nil	Without blocking disk (Without laser marking)
P	With SUP blocking disk
E	With EXH blocking disk
PE	With SUP/EXH blocking disk

* Laser printed blocking disk symbol on the piping surface of the fitting of A and B port.
For blocking disks, refer to "Manifold Options" on page 34.

Manifold block port size
[Thread piping/One-touch fitting (Metric/Inch size)]

Symbol	Fitting specifications		Manifold block port size	
			2-port type	5-port type
			A, B port	P, A, B, EA, EB port
02F	Without fitting		G1/4 Thread piping	
B8	Metric size Threaded One-touch fitting	Brass fitting	ø8*1	
B10			ø10	
G8		Stainless steel fitting	ø8*1	
G10	ø10			
BN9	Inch size Threaded One-touch fitting	Brass fitting	ø5/16"*1	
BN11			ø3/8"	
GN9		Stainless steel fitting	ø5/16"*1	
GN11			ø3/8"	

*1 ø8 and ø5/16" One-touch fitting are common for mm and inch size.

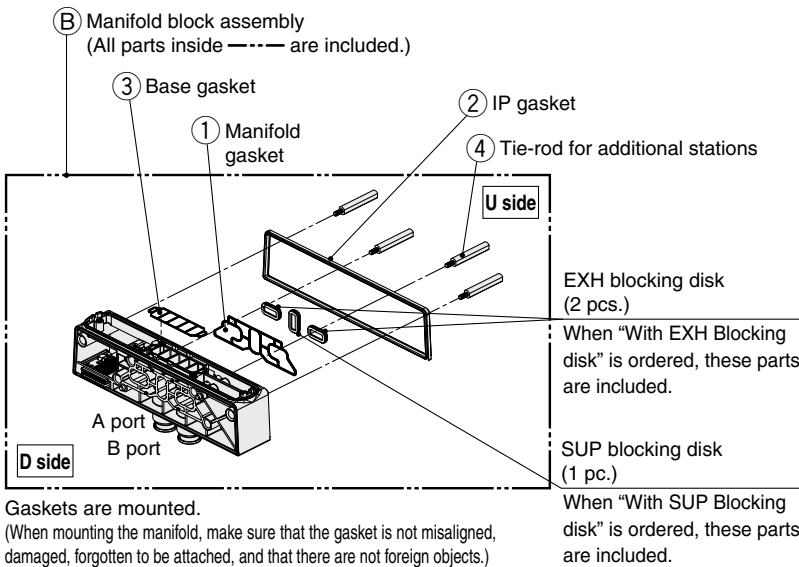

Manifold block assembly accessories and the number of accessories

Accessories	Quantity
① Manifold gasket	1 pc. (Mounted)
② IP gasket	1 pc. (Mounted)
③ Base gasket	1 pc. (Mounted)
④ Tie-rod for additional stations	4 pcs. (Included)

* Refer to page 26 for ordering single unit.

Manifold Parts Nos.

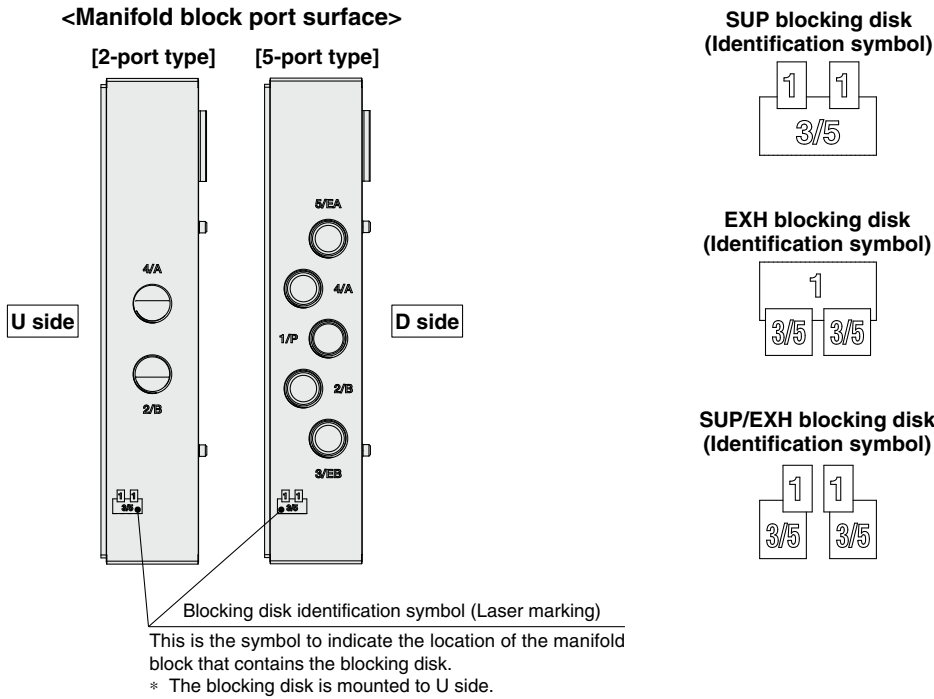

[2-port / 5-port types mixed]

<Example>

Use a blocking disk in the 1(P) SUP passage for each additional different pressure required.
 Use blocking disk in the 5(EA)/3(EB) EXH passages for individual valve exhaust.
 5-port type manifold blocks can be used to provide additional SUP/EXH if low flow rate occurs.
 * Specify **the arrangement and blocking disk position in the manifold specification sheet.**

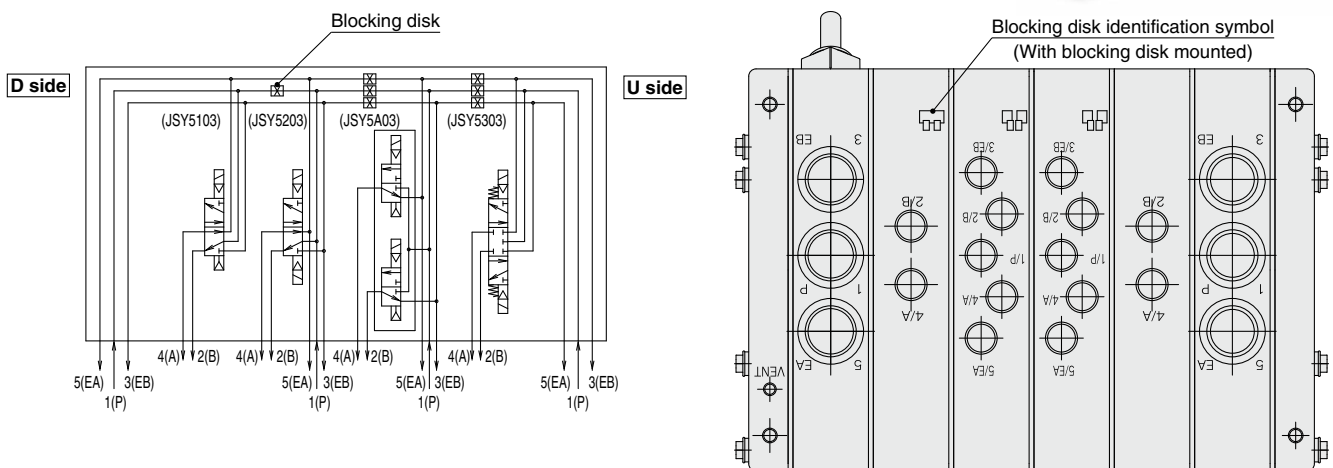

Valve

JSY5000-H

Sub-plate

Manifold Exploded View

Sub-plate Exploded View

EX430

Fittings, Plugs, Tube Releasing Tools

Manifold Options

Made to Order

Specific Product Precautions

JSY5000-H Series

Manifold Parts Nos.

① D side end block assembly

JSY51M – 103P – 1 A – M5

Pilot type

Nil	Internal pilot
R*1	External pilot

*1 The external pilot specification should be ordered as made to order.

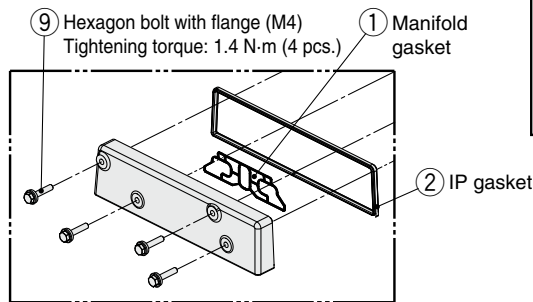

Gaskets are mounted.
(Make sure that the washers are assembled to the hexagon bolt with flange. When mounting the manifold, make sure that the gasket is not misaligned, damaged, forgotten to be attached, and that there are not foreign objects.)

D side end block port location

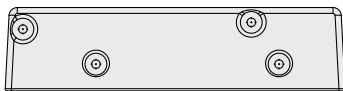

VENT port (M5)
(Common to internal/external pilot)

PE port (G1/8)
(External pilot only)

X port (G1/8)

For internal pilot VENT port size

[Thread piping/One-touch fitting (Metric/Inch size)]

Symbol	Fitting specifications	One-touch fitting size
M5	Without fitting	M5, Thread piping
B4	Metric size Threaded	Brass fitting
G4	One-touch fitting	Stainless steel fitting
BN3	Inch size Threaded	Brass fitting
GN3	One-touch fitting	Stainless steel fitting
		One-touch fitting size
		ø4*1
		ø5/32**1

*1 For the VENT port of ø4 and ø5/32", the same fitting is used for them.

For external pilot "R" (Made to order) VENT, X, PE port size

[Thread piping/One-touch fitting (Metric/Inch size)]

Symbol	Fitting specifications	One-touch fitting size	
		VENT port	X, PE port
01F	Without fitting	M5, Thread piping	G1/8, Thread piping
B6	Metric size Threaded	ø4*1	ø6
G6	One-touch fitting		
BN7	Inch size Threaded	ø5/32**1	ø1/4"
GN7	One-touch fitting		

*1 For the VENT port of ø4 and ø5/32", the same fitting is used for them.

D side end block assembly accessories and the number of accessories

Accessories	Quantity
① Manifold gasket	1 pc. (Mounted)
② IP gasket	1 pc. (Mounted)
⑨ Hexagon bolt with flange (M4) (With washer)	4 pcs. (Included)

* Refer to page 26 for ordering single unit.

② U side end block assembly

JSY51M – 103P – 2A

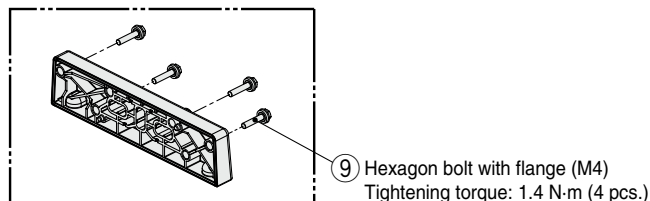

⑨ Hexagon bolt with flange (M4)
Tightening torque: 1.4 N-m (4 pcs.)

U side end block assembly accessories and the number of accessories

Accessories	Quantity (Included)
⑨ Hexagon bolt with flange (M4) (With washer)	4 pcs.

* Refer to page 26 for ordering single unit.

Manifold Parts Nos.

④ Valve cover assembly (For manifold/sub-plate)

JSY51M-104P-1A-1

Type of actuation (Symbol laser marking)

Nil	Without laser marking	
1	2-position	Single
2		Double
3	3-position	Closed center
4		Exhaust center
5		Pressure center
A*1	4-position dual	N.C./N.C.
B*1		N.O./N.O.
C*1		3-port

Pilot type

Nil	Internal pilot
R*1	External pilot

*1 The external pilot specification should be ordered as made to order.

*1 External pilot specification is not applicable for 4-position dual 3-port valves.

* Laser printed JIS symbols corresponding to the valve switching method. (Part A below)

⑦ Hexagon bolt with flange (M3) (With washer)
Tightening torque: 0.8 N·m (2 pcs.)

④ Valve cover assembly

⑧ Cover gasket

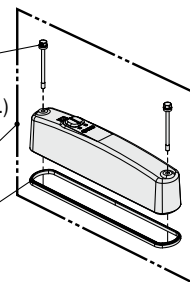

The gasket is mounted.

(Make sure that the washers are assembled to the hexagon bolt with flange. When mounting the manifold, make sure that the gasket is not misaligned, damaged, forgotten to be attached, and that there are not foreign objects.)

Valve cover assembly with valve (For manifold/sub-plate)

JSY503(R)(T)-5-HC

Same as the valve part number

With valve cover

⑦ Hexagon bolt with flange (M3) (With washer)
Tightening torque: 0.8 N·m (2 pcs.)

④ Valve cover assembly

⑧ Cover gasket

Valve cover assembly with valve

A Symbol (Laser marking)

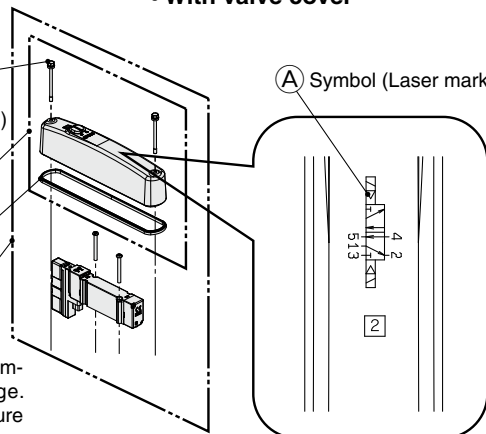

The gasket is mounted.

(Make sure that the washers are assembled to the hexagon bolt with flange. When mounting the manifold, make sure that the gasket is not misaligned, damaged, forgotten to be attached, and that there are not foreign objects.)

* [2] is an identification symbol for the assembly for the production department of SMC.

Valve cover assembly/ Valve cover assembly with valve accessories and the number of accessories

Accessories	Quantity (Mounted)
⑦ Hexagon bolt with flange (M3) (With washer)	2 pcs.
⑧ Cover gasket	1 pc.

* Refer to page 26 for ordering single unit.

⑤ U side SUP/EXH block assembly

JSY51M-101P-3A-04F

• 1(P), 5(EA), 3(EB) port size

[Thread piping/One-touch fitting (Metric/Inch size)]

Symbol	Fitting specifications		P, EA, EB port One-touch fitting size
04F	Without fitting		G1/2, Thread piping
B12	Metric size Threaded One-touch fitting	Brass fitting	ø12
B16			ø16
G12		Stainless steel fitting	ø12
G16			ø16
BN11	Inch size Threaded One-touch fitting	Brass fitting	ø3/8"
BN13			ø1/2"
GN11		Stainless steel fitting	ø3/8"
GN13			ø1/2"

U side SUP/EXH block assembly accessories and the number of accessories

Accessories	Quantity
① Manifold gasket	1 pc. (Mounted)
② IP gasket	1 pc. (Mounted)
④ Tie-rod for additional stations	4 pcs. (Included)

* Refer to page 26 for ordering single unit.

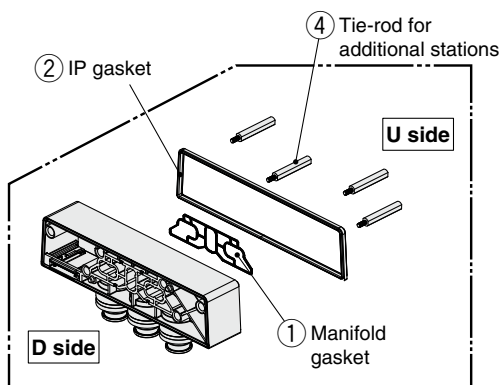

Gaskets are mounted.

(When mounting the manifold, make sure that the gasket is not misaligned, damaged, forgotten to be attached, and that there are not foreign objects.)

Valve

JSY5000-H

Sub-plate

Manifold Exploded View

Sub-plate Exploded View

EX430

Fittings, Plugs, Tube Releasing Tools

Manifold Options

Made to Order

Specific Product Precautions

JSY5000-H Series

Sub-plate (Single Unit) Exploded View

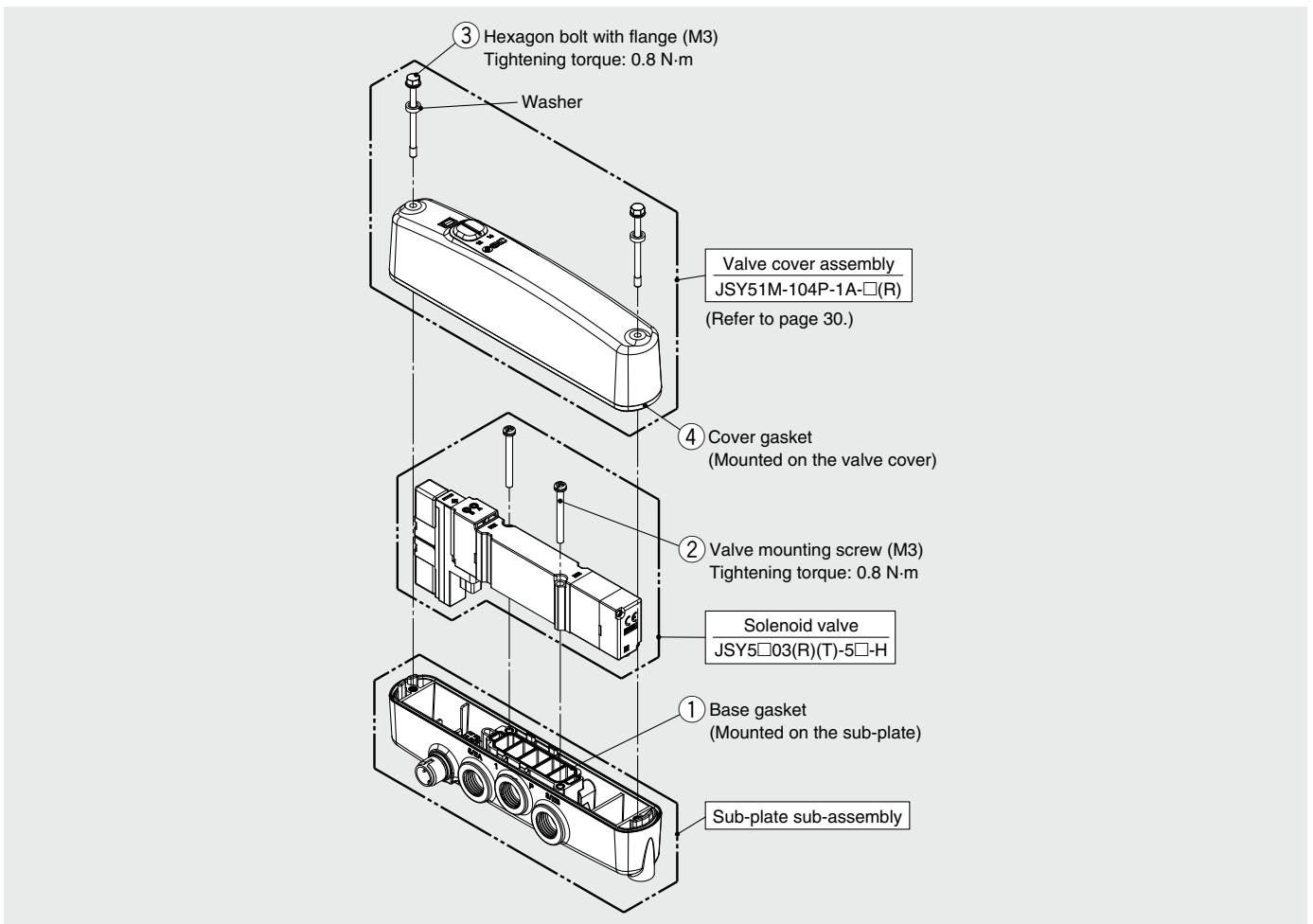

Sub-plate Parts Nos.

No.	Description	Part no.	Note
①	Base gasket	JSY51M-9P-1A	For 10 valves (10 pcs.)
②	Valve mounting screw	JSY51V-23-1A (M3 x 29)	For 10 valves (20 pcs.)
③	Hexagon bolt with flange (M3) (With washer) (For valve cover)	JSY51M-123P-1A (M3 x 40)	For 5 valves (10 pcs.)
④	Cover gasket (For valve cover)	JSY51M-109P-2A	For 10 valves (10 pcs.)

■ Mounting leg (2 pcs./set): For sub-plate

JSY51M-115P-2A

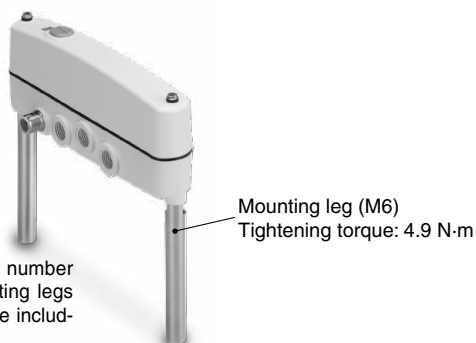

* When the sub-plate part number (L) is ordered, the mounting legs are not assembled but are included in the same package.

Fieldbus System: For Output

EX430 Series



How to Order SI Units

EX430-SIL1

EX430

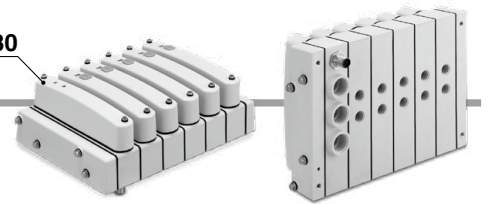

Communication protocol

Symbol	Protocol	Output polarity	Communication connector	Manifold symbol
IL1	IO-Link	Source/PNP (Negative common)	M12*1	SKAN

*1 The M12 connector is located on the SUP/EXH block on the manifold D side.

Specifications

Model		EX430-SIL1
Applicable system	Protocol	IO-Link (Class B)
	Version	V1.1
	Configuration file*1	IODD file
I/O occupation area (Inputs/Outputs)		0/32, 16/32*2
Communication speed		COM3/COM2*2
Communication connector specification		M12*3
Power supply for control	Power supply voltage	18 to 30 VDC
	Internal current consumption	50 mA or less
Power supply for output	Power supply voltage	22.8 to 26.4 VDC
	Output type	Source/PNP (Negative common)
Output	Number of outputs	32
	Load	Solenoid valve with surge voltage suppressor of 24 VDC, 0.4 W or less (SMC)
	Supplied voltage	24 VDC
	Supplied current	Max. 0.54 A
	Operating temperature range	-10 to 50°C
Environmental resistance	Operating humidity range	35% to 85% RH (No condensation)
	Withstand voltage	500 VAC for 1 minute between terminals and housing
	Insulation resistance	10 MΩ or more (500 VDC measured via megohmmeter) between terminals and housing
Standards		CE marking (EMC directive/RoHS directive)
Weight		100 g

*1 The configuration file can be downloaded from the SMC website: <https://www.smcworld.com>

*2 A selection can be made using the setting switch.

*3 The M12 connector is located on the SUP/EXH block on the manifold D side.

Y Branch Connector for IO-Link

This connector is used to supply power to the valve manifold by branching the IO-Link communication cable in cases where a port class A IO-Link master is used.

This branch connector has an IP67 enclosure.

[Click here for details.](#)



Dimensions

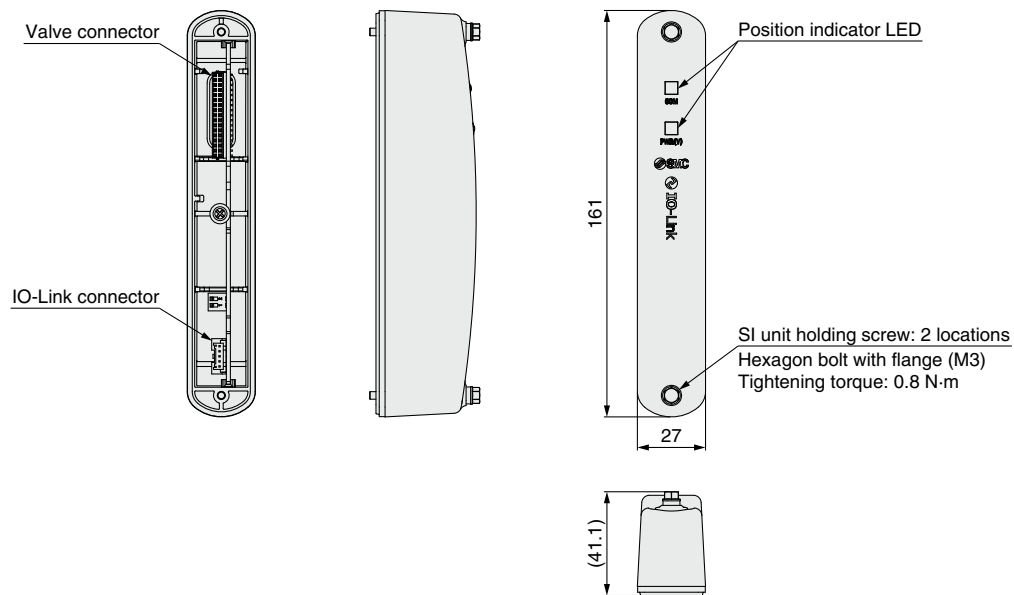

Valve

JSY5000-H

Sub-plate

Manifold Exploded View

Sub-plate Exploded View

EX430

Fittings, Plugs, Tube Releasing Tools

Manifold Options

Made to Order

Specific Product Precautions

JSY5000-H Series

One-touch Fittings, Plugs, Tube Releasing Tools

■ FDA Compliant Metal One-touch Fittings Hexagon Socket Head Male Connector

Port size			Brass C3604 (Electroless nickel plating)	Stainless steel 316	
Metric size	Manifold block	2-port type: 4(A), 2(B) port	$\phi 8^{*1}$	KQB2S08-G02-F	KQG2S08-G02-F
		5-port type: 1(P), 4(A), 2(B), 5(EA), 3(EB) port	$\phi 10$	KQB2S10-G02-F	KQG2S10-G02-F
	SUP/EXH block	1(P), 5(EA), 3(EB) port	$\phi 12$	KQB2S12-G04-F	KQG2S12-G04-F
			$\phi 16$	KQB2S16-G04-F	KQG2S16-G04-F
D side end block	VENT port	$\phi 4^{*2}$	KQB2S04-M5-F	KQG2S04-M5-F	
		X, PE port	$\phi 6$	KQB2S06-G01-F	KQG2S06-G01-F
Inch size	Manifold block	2-port type: 4(A), 2(B) port	$\phi 5/16^{*1}$	KQB2S08-G02-F	KQG2S08-G02-F
		5-port type: 1(P), 4(A), 2(B), 5(EA), 3(EB) port	$\phi 3/8"$	KQB2S11-G02-F-X73	KQG2S11-G02-F-X73
	SUP/EXH block	1(P), 5(EA), 3(EB) port	$\phi 3/8"$	KQB2S11-G04-F-X73	KQG2S11-G04-F-X73
			$\phi 1/2"$	KQB2S13-G04-F-X73	KQG2S13-G04-F-X73
	D side end block	VENT port	$\phi 5/32^{*2}$	KQB2S04-M5-F	KQG2S04-M5-F
			X, PE port	$\phi 1/4"$	KQB2S07-G01-F-X73

*1 For the 4(A) and 2(B) port of $\phi 8$ or $\phi 5/16"$, the same fitting is used for them.

*2 For the VENT port of $\phi 4$ and $\phi 5/32"$, the same fitting is used for them.



Metal One-touch fitting

■ FDA Compliant Metal Plugs

When the plug is used, use it with a One-touch fitting.

Port size			Brass C3604 (Electroless nickel plating)	Stainless steel 316	
Metric size	Manifold block	2-port type: 4(A), 2(B) port	$\phi 8^{*1}$	KQB2P-08-F	KQG2P-08
		5-port type: 1(P), 4(A), 2(B), 5(EA), 3(EB) port	$\phi 10$	KQB2P-10-F	KQG2P-10
	SUP/EXH block	1(P), 5(EA), 3(EB) port	$\phi 12$	KQB2P-12-F	KQG2P-12
			$\phi 16$	KQB2P-16-F	KQG2P-16
D side end block	VENT port	$\phi 4^{*2}$	KQB2P-04-F	KQG2P-04	
		X, PE port	$\phi 6$	KQB2P-06-F	KQG2P-06
Inch size	Manifold block	2-port type: 4(A), 2(B) port	$\phi 5/16^{*1}$	KQB2P-08-F	KQG2P-08
		5-port type: 1(P), 4(A), 2(B), 5(EA), 3(EB) port	$\phi 3/8"$	KQB2P-11-F	KQG2P-11
	SUP/EXH block	1(P), 5(EA), 3(EB) port	$\phi 3/8"$	KQB2P-11-F	KQG2P-11
			$\phi 1/2"$	KQB2P-13-F	KQG2P-13
	D side end block	VENT port	$\phi 5/32^{*2}$	KQB2P-04-F	KQG2P-04
			X, PE port	$\phi 1/4"$	KQB2P-07-F

*1 For the 4(A) and 2(B) port of $\phi 8$ or $\phi 5/16"$, the same fitting is used for them.

*2 For the VENT port of $\phi 4$ and $\phi 5/32"$, the same fitting is used for them.



Metal plug

■ Tube Releasing Tools (This tool is used for removing the tube from the 4(A) and 2(B) port.)

Part no.	TG-0608	TG-1012
Applicable tubing O.D.	$\phi 6/\phi 8$	$\phi 10/\phi 12$

* Tube releasing tools are not applicable for all port sizes.



TG-0608

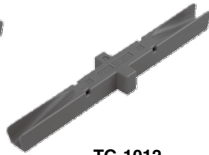

TG-1012

Tube releasing tools

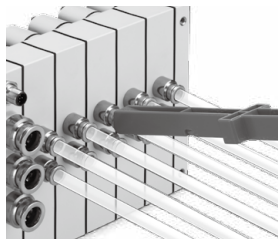

For details on the tube removal procedure, refer to the JSY1000/3000/5000 Web Catalog.



The catalog can be viewed here.

JSY5000-H Series Manifold Options

■ Blanking plate

[With two mounting screws]

Used when valve additions are expected or for maintenance

Blanking plate (Single unit)

JSY51M – 26P – 1A

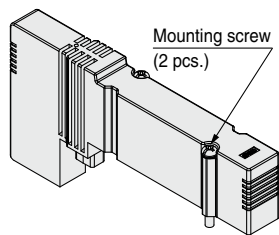

JSY51M-26P-1A

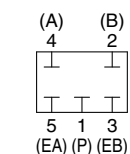

Circuit diagram

Valve cover assembly with blanking plate

JSY51M – 26P – 1A C

With valve cover

For the valve cover assembly, refer to "Manifold Parts Nos." on page 30.

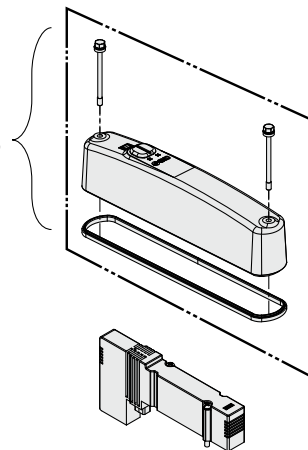

■ SUP/EXH blocking disk

[SUP blocking disk]

By inserting the SUP blocking disk in the pressure supply passage of the manifold valve, can provide two different high and low pressure in one manifold.

[EXH blocking disk]

By inserting the EXH blocking disk in the exhaust passage of the manifold valve, can separate the exhaust from the valve so it does not affect the other valves. It can also be used for the manifold for the positive pressure and vacuum mixed manifold. **(2 pieces are required to block EA/EB both sides of the EXH.)**

* When ordering a manifold, if the blocking disk is ordered at the same time in the manifold specifications, the laser printed blocking disk symbol will be displayed in the manifold block assembly that includes the blocking disk. Refer to the manifold block assembly on page 27 for the contents.

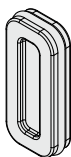

Series	SUP blocking disk	EXH blocking disk
JSY5000	JSY51M-40P-2A	JSY51M-40P-2A

Valve

JSY5000-H

Sub-plate

Manifold
Exploded View

Sub-plate
Exploded View

EX430

Fittings, Plugs,
Tube Releasing Tools

Manifold
Options

Made to Order

Specific Product
Precautions

JSY5000-H Series

Made to Order

Please contact SMC for detailed dimensions, specifications, and delivery times.



1 External Pilot

How to Order Manifolds Refer to the How to Order manifolds for each type on page 11.

Caution This is an IP69K compliant product. The manifold and valves are ordered as a set.

Lead wire type

JJ5SY5 - H11L1 [] - [] [] R - [] []

Fieldbus type (IO-Link)

JJ5SY5 - H11SKAN - [] [] R - [] []

• **Pilot type**

R	External pilot
---	----------------

How to Order Valves

JSY5 [] 03 R [] - 5 [] [] - H

• **Coil type (Refer to 2.)**
 • **Pilot type**

R	External pilot
---	----------------

- * External pilot specification is not applicable for 4-position dual 3-port valves.
- * When pilot type "R" is selected, select the external pilot type "R" for the manifold pilot type.

How to Order Sub-plates (With Valve/Valve Cover) Refer to the How to Order sub-plates on page 20.

JSY5 [] 03 R [] - 5 [] [] - H - WO - U [] []

• **Coil type (Refer to 2.)**
 • **Pilot type**

R	External pilot
---	----------------

- * External pilot specification is not applicable for 4-position dual 3-port valves.

2 Coil Type: With Power-Saving Circuit (Continuous Duty Type, 0.1 W)

Be sure to select the power-saving circuit type when the valve is continuously energized for long periods of time. Be careful of the energizing time when the power-saving circuit is selected. Refer to page 37 for details.

How to Order Valves

JSY5 [] 03 [] T - 5 [Z] [] - H

Pilot type (See above.)

• **Coil type**

T	With power-saving circuit (Continuous duty type)
---	--

- * Only "Z" and "NZ" types are available with a power-saving circuit.

• **Light/surge voltage suppressor and common specification**

Symbol	With light	Surge voltage suppressor	Common specification
Z	●	●	Positive common
NZ			Negative common



JSY5000-H Series

Specific Product Precautions 1

Be sure to read this before handling the products.

Environment

Warning

- Do not use valves in atmospheres of corrosive gases, chemicals*¹, sea water, water vapor, or where there is direct contact with any of these.

*1 Check section on cleaning and the product component list of the external materials used, and ensure compatibility with any chemicals used in the cleaning solution.

- Avoid installing and using inside a food zone.

- Not installable
Food zone: An environment where food which will be sold as merchandize, directly touches the manifold parts
- Installable
Splash zone: An environment where food which will not be sold as merchandize, directly touches the manifold parts
- Non-food zone: An environment where there is no contact with food

IP69K (IEC/EN 60529/ISO 20653) compliant product

- IP69K is only guaranteed to the factory condition (finished as a manifold).
- IP69K compliant products are protected against dust and high pressure hot water. However, when using the valve, keep within the ambient temperature and fluid temperature. (No freezing)
- IPX9K compliant products are protected against dust and high pressure hot water jetwash.
When cleaning the manifold, it is recommended to keep the distance from the washer nozzle to the manifold at least 20 cm. Wash the manifold while moving the nozzle. Do not fix the cleaning point to one place.
- Refer to the tightening torque in the disassembly drawing of the manifold (p. 25) when increasing or decreasing the number of stations for IP69K compliance. When installing the manifold, make sure that the gasket is not misaligned, forgotten to be attached, and that there are not foreign objects.

How to Use

Caution

VENT port

- A VENT port is installed on the manifold so that even if a valve leaks, the leaked pressure does not accumulate inside.
- Prevent liquid from entering the VENT port.
- Do not block the VENT port. If the VENT port is used with the port closed, internal pressure may build up and the product gasket may come off and IP69K is not satisfied.
- Do not pressurize the VENT port. The sealing performance of the gasket will be reduced and the IP69K may not be satisfied.
- Do not pipe the VENT port and the exhaust port (3/5 port) in the same piping. The back pressure of the exhaust port may be applied to the VENT port, increasing the internal pressure.



How to Use

Caution

Metal One-touch fittings

- When tightening the hexagon socket head male connector, use a suitable hexagon wrench, and connect the piping carefully so as not to deform or damage the inside of the connector. If the inside of the connector is deformed or damaged, the falling out of tubes may occur.
- Uni thread fittings cannot be used. When using Uni thread fittings, the tightening load on the chamfered part of the female thread on the manifold side can cause the female thread side to deform or break.
- Tighten fittings with the proper tightening torques in the table below.

Hexagon socket head male connector (KQB2S)



Connection port	Connection thread size	Proper tightening torque [N·m]
VENT	M5	1 to 1.5
X, PE	G1/8	2.9 to 3.2
2(B), 4(A)	G1/4	5.7 to 6.3
1(P), 3(EB), 5(EA)	G1/2	14.3 to 15.8

Manual override

Use a rounded tool (such as a ballpoint hex wrench) for manual override operations. Manipulating manual override with a sharp tool will damage the manual gasket and the IP69K is not satisfied.

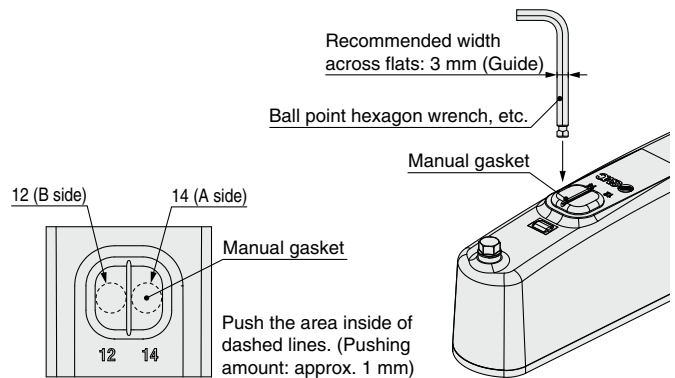

Valve/Manifold Parts Mounting

Caution

Mount it so that there is no slippage or deformation in gaskets, and tighten with the tightening torque shown below.

Thread size	Tightening torque	Tightening location
M3	0.8 N·m	Valve, Valve cover, SI unit
M4	1.4 N·m	End block
M6	4.9 N·m	Mounting leg (Option)

Valve

JSY5000-H

Sub-plate

Manifold Exploded View

Sub-plate Exploded View

EX430

Fittings, Plugs, Tube Releasing Tools

Manifold Options

Made to Order

Specific Product Precautions



JSY5000-H Series Specific Product Precautions 2

Be sure to read this before handling the products.

Used as a 3-Port Valve

⚠ Caution

■ In case of using a 5-port valve as a 3-port valve

The JSY5000 series can be used as normally closed (N.C.) or normally open (N.O.) 3-port valves by closing one of the cylinder ports 4(A) or 2(B) with a plug. However, they should be used with the exhaust ports kept open. Use them when a double solenoid type 3-port valve is required.

Plug position		B port	A port
Type of actuation		N.C.	N.O.
Number of solenoids	Single	(A)4 2(B) (EA)5 1 3(EB) (P)	(A)4 2(B) (EA)5 1 3(EB) (P)
	Double	(A)4 2(B) (EA)5 1 3(EB) (P)	(A)4 2(B) (EA)5 1 3(EB) (P)

Light/Surge Voltage Suppressor

⚠ Caution

■ Polar type

Positive common Single solenoid

Light/surge voltage suppressor (□Z)

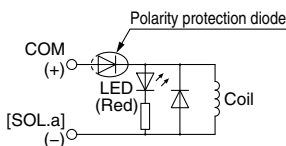

Negative common Single solenoid

Light/surge voltage suppressor (□NZ)

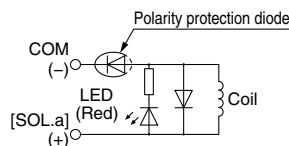

Positive common

Double solenoid, 3-position, 4-position

Light/surge voltage suppressor (□Z)

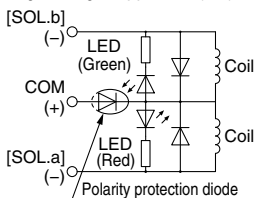

Negative common

Double solenoid, 3-position, 4-position

Light/surge voltage suppressor (□NZ)

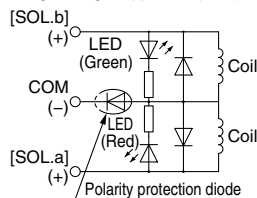

* Serial transmission type is not applicable for the positive common.

■ Non-polar type

With light/surge voltage suppressor (□U)

Single solenoid

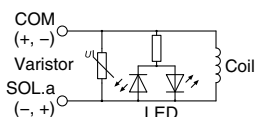

Double solenoid

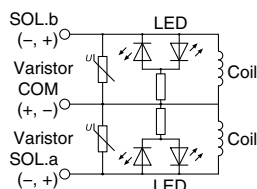

Light/Surge Voltage Suppressor

⚠ Caution

■ With power-saving circuit (Made to order)

Power consumption is decreased to approx. 1/4 compared with the standard product by reducing the wattage required to hold the valve in an energized state. (Effective energizing time is over 67 ms at 24 VDC.)

Electric circuit diagram (With power-saving circuit)
In the case of single solenoid

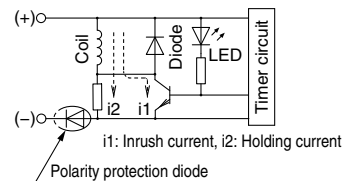

The circuit shown above reduces the power consumption for holding in order to save energy. Refer to the electrical power waveform as shown below.

<Electrical power waveform with power-saving circuit>

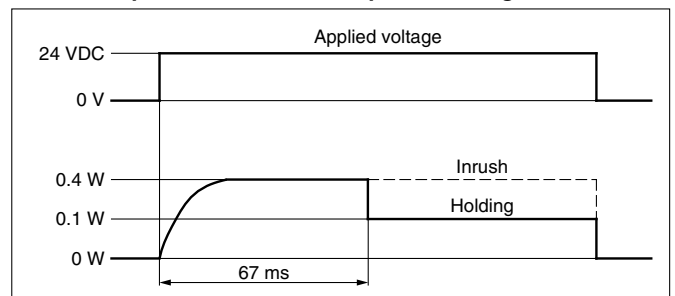

Since the voltage will drop by approx. 0.5 V due to the transistor, pay attention to the allowable voltage fluctuation. (For details, refer to the solenoid specifications of each type of valve.)

Residual voltage of the surge voltage suppressor

* If a varistor or diode surge voltage suppressor is used, there is some residual voltage to the protection element and rated voltage. Therefore, refer to the table below and pay attention to the surge voltage protection on the controller side. Also, since the response time does change, refer to the response time on page 7.

Residual Voltage

Surge voltage suppressor	24 VDC
Z	Approx. 1 V
U	Approx. 47 V

Continuous Duty

⚠ Caution

If a valve is energized continuously for long periods of time, the rise in temperature due to heat-up of the coil assembly may cause a decline in solenoid valve performance, reduce service life, or have adverse effects on peripheral equipment. If the valve is energized continuously or if the A side and B side of the dual 3-port valve are energized simultaneously, be sure to use a valve with power-saving circuit.

Energization of a 2-Position Double Solenoid Valve

⚠ Caution

To avoid operation failure, do not energize the A side and B side of 2-position double solenoid valve at the same time.



JSY5000-H Series Specific Product Precautions 3

Be sure to read this before handling the products.

Countermeasure for Surge Voltage Intrusion

Caution

Surge voltage intrusion

With non-polar type valves, at times of sudden interruption of the loading power supply, such as emergency shutdown, surge voltage intrusion may be generated from loading equipment with a large capacity (power consumption), and a valve in a de-energized state may switch over (see Fig. 1). When installing a breaker circuit for the loading power supply, consider using a valve with polarity (with polarity protection diode), or install a surge absorption diode between the loading equipment COM line and the output equipment COM line (see Fig. 2).

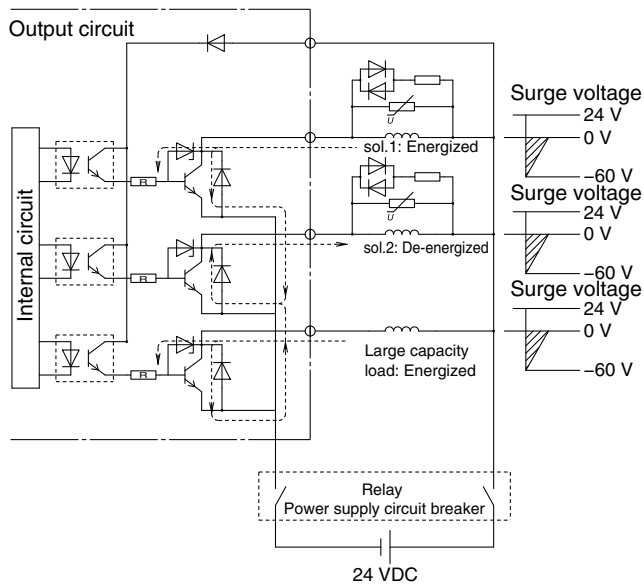

Fig. 1 Surge intrusion circuit example (NPN outlet example) (24 VDC)

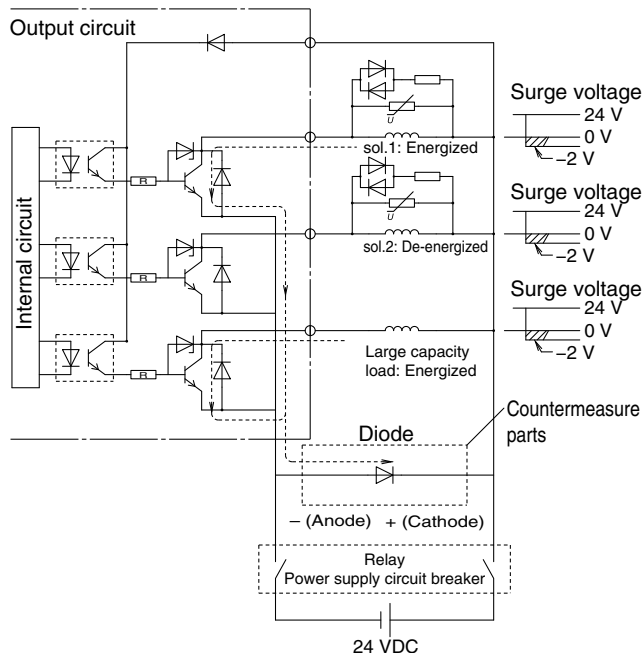
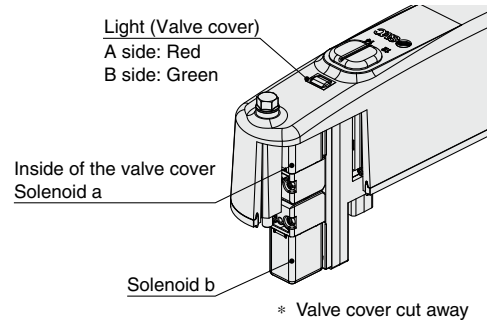

Fig. 2 Surge intrusion countermeasure example (NPN outlet example) (24 VDC)

Light Indication

Caution

When equipped with indicator light and surge voltage suppressor, the light window turns red when solenoid a is energized, and it turns green when solenoid b is energized.



Substrate inside Manifolds

Caution

The substrate inside of manifolds cannot be taken apart. Attempting to do so may damage parts.

Other Tube Brands

Caution

1. When using other than SMC brand tube, confirm that the following specifications are satisfied with respect to the tube outside diameter tolerance.

- 1) Nylon tubing Within ± 0.1 mm
- 2) Soft nylon tubing Within ± 0.1 mm
- 3) Polyurethane tubing Within $+0.15$ mm, Within -0.2 mm

Do not use tubing which does not satisfy the specified tubing O.D. accuracy, or tubing with an I.D., material, hardness, or surface roughness that differs from SMC's tubing. Please consult SMC if anything is unclear. It may cause difficulty in connecting the tubing, leakage, disconnection of the tubing, or fitting damage.

When used with tubing other than those from SMC, due to their properties, the KQG2 and KQB2 are not subject to warranty.

2. When using fittings other than those from SMC, be certain to confirm that the operating conditions are such that no problems will arise.

Valve

JSY5000-H

Sub-plate

Manifold Exploded View

Sub-plate Exploded View

EX430

Fittings, Plugs, Tube Releasing Tools

Manifold Options

Made to Order

Specific Product Precautions



JSY5000-H Series

Specific Product Precautions 4

Be sure to read this before handling the products.

One-touch Fittings

⚠ Caution

■ Installation and removal of tubing for One-touch fittings

1) Installation of tubing

- (1) Cut the tubing perpendicularly, being careful not to damage the outside surface. Use an SMC tube cutter TK-1, 2, 3, 5, or 6. Do not cut the tubing with pliers, nippers, scissors, etc., otherwise the tubing will be deformed and problems may result. Allow some extra length in the tube.
- (2) The outside diameter of the polyurethane tubing swells when internal pressure is applied to it. Therefore, it may be impossible to re-insert the tubing into the One-touch fitting. Check the tubing outside diameter, and when the accuracy of the outside diameter is +0.07 mm or larger for $\phi 2$, +0.15 mm or larger for other sizes, re-insert it into the One-touch fitting without cutting the tubing. When the tubing is re-inserted into the One-touch fitting, confirm that the tubing goes through the release button smoothly.
- (3) Grasp the tubing, and slowly push it straight (0 to 5°) into the One-touch fitting until it comes to a stop.
- (4) Pull the tubing back gently to make sure it has a positive seal. Insufficient installation may cause air to leak or the tubing to release.

As a guide for checking if the tubing is pulled out or not, refer to the following table.

Tubing size	Tensile force of tubing [N]
$\phi 2$, $\phi 3.2$, $\phi 1/8"$	5
$\phi 4$, $\phi 5/32"$, $\phi 3/16"$	8
$\phi 6$, $\phi 1/4"$	12
$\phi 8$, $\phi 5/16"$	20
$\phi 10$, $\phi 3/8"$	30
$\phi 12$, $\phi 1/2"$	35
$\phi 16$	50

2) Removal of tubing

Use the release tool when the removal of tube is difficult due to the tube size. Refer to page 33 for releasing tools.

- (1) Push the release button flange evenly and sufficiently to release the tube. Do not push in the tubing before pressing the release button.
- (2) Pull out the tubing while keeping the release button depressed. If the release button is not held down sufficiently, the tubing cannot be withdrawn.
- (3) To reuse the tubing, remove the previously lodged portion of the tubing. If the lodged portion is left on without being removed, it may result in air leakage and make the removal of the tubing difficult.

Installation

⚠ Caution

Even though the inlet pressure is within the operating pressure range, when the piping diameter is restricted due to size reduction of supply port 1(P), the flow will be insufficient. In this case, the valve does not switch completely and the cylinder may malfunction.

Maintenance

⚠ Caution

1. Regular inspection and tightening of the hexagon bolts with flange is recommended at 3 months intervals, to satisfy IP69K. (Recommended inspection interval: 3 months)

For the tightening location and tightening torque, see the exploded view of the manifold (p. 25).

Please replace the washer if it is damaged.

2. When disassembling by removing the hexagon bolt with flange, make sure that there is not moisture on the outer surface of the product. If the product is disassembled or assembled with moisture attached, moisture may enter the inside of the manifold and cause damage.

3. Make sure that the washers are in good condition, in position and assembled when tightening the hexagon bolt with flange.

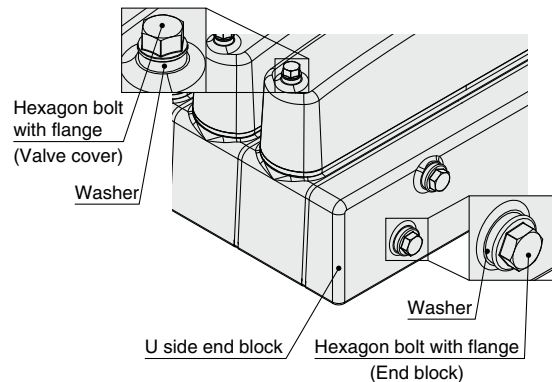



EX430 Series

Specific Product Precautions 1

Be sure to read this before handling the products.

Design / Selection

⚠ Warning

- 1. Do not use beyond the specification range.**
Using beyond the specification range may result in a fire, malfunction, or damage to the system.
Check the specifications before operation.
- 2. When using for an interlock circuit:**
 - **Provide a multiple interlock system which is operated by another system (such as a mechanical protection function).**
 - **Perform an inspection to confirm that it is working properly.**
Failure to do so may result in possible injuries due to malfunction.

⚠ Caution

- 1. Use within the specified voltage range.**
Using beyond the specified voltage range is likely to cause product damage or malfunction.
- 2. Do not install in places where it can be used as a foothold.**
Applying any excessive load such as stepping on the product by mistake or placing a foot on it will cause it to break.
- 3. Keep the surrounding space free for maintenance.**
When designing a system, take into consideration the amount of free space needed to perform maintenance.
- 4. Beware of inrush currents when the power supply is turned on.**
Some connected loads can apply an initial charge current which will trigger the over current protection function, causing the product to malfunction.

Mounting

⚠ Caution

- 1. When handling and assembling products:**
 - **Do not apply excessive force to the product when disassembling.**
The connecting parts of the product are firmly joined with seals.
 - **When joining units, take care not to get your fingers caught between the products.**
Injury may result.
- 2. Do not drop, bump, or apply excessive impact to the product.**
Doing so may result in damage, equipment failure, or malfunction.

Mounting

⚠ Caution

- 3. Observe the tightening torque range.**
Tightening outside of the allowable torque range will likely damage the screw.
IP69K cannot be guaranteed if the screws are not tightened to the specified torque.
- 4. When lifting a large solenoid valve manifold, take care to avoid causing stress to the valve connection joint.**
The connection parts of the product may be damaged.
Because the product may be heavy, carrying and installation should be performed by more than one operator to avoid strain or injury.
- 5. When installing the product, mount it on a flat surface.**
Torsion in the whole product may lead to problems such as air leakage or contact failure.

Wiring

⚠ Caution

- 1. Avoid repeatedly bending or stretching the cable and applying heavy objects or force to it.**
Wiring where repeated bending and tensile stress are applied to the cable may result in circuit breakage.
- 2. Avoid miswiring.**
If miswired, there is a danger of malfunction or damage to the product.
- 3. Do not wire while energizing the product.**
There is a danger of malfunction or damage to the product or input/output device.
- 4. Avoid wiring the power line and high-voltage line in parallel.**
Signal line noise or surge from the power line or high-pressure line could cause a malfunction.
Wiring of the product or input/output device and the power line or high-voltage line should be separated from each other.
- 5. Check the wiring insulation.**
Defective insulation (contact with other circuits, improper insulation between terminals, etc.) may cause damage to the product or input/output device due to excessive voltage or current.

Valve

JSY5000-H

Sub-plate

Manifold Exploded View

Sub-plate Exploded View

EX430

Fittings, Plugs, Tube Releasing Tools

Manifold Options

Made to Order

Specific Product Precautions



EX430 Series

Specific Product Precautions 2

Be sure to read this before handling the products.

Wiring

Caution

6. **When the product is installed in machinery/equipment, provide adequate protection against noise by using noise filters, etc.**

Noise in signal lines may cause a malfunction.

7. **When connecting wires, prevent the entry of water, solvent, or oil from the connector section.**

Failure to do so may result in damage, equipment failure, or malfunction.

8. **Avoid wiring patterns in which excessive stress is applied to the connector.**

Failure to do so may result in equipment failure or malfunction due to contact failure.

Operating Environment

Warning

1. **Do not use in atmospheres containing inflammable or explosive gases.**

Use in such atmospheres is likely to cause a fire or explosion. This product is not explosion proof.

Caution

1. **Provide adequate protection when operating in locations such as the following.**

Failure to do so may cause a malfunction or equipment failure. The effect of countermeasures should be checked in individual equipment and machines.

- 1) Where noise is generated by static electricity, etc.
- 2) Where there is a strong electric field
- 3) Where there is a danger of exposure to radiation
- 4) When in close proximity to power lines or high-voltage lines

2. **Do not use in environments where oil and chemicals are used.**

Operating in environments where coolants, cleaning solvents, various oils, or chemicals are present may cause adverse effects (damage, malfunction, etc.) to the product even within a short period of time.

3. **Do not use in environments where the product could be exposed to corrosive gases or liquids.**

Use in such environments may cause product damage or malfunction.

Operating Environment

Caution

4. **Select the proper type of enclosure according to the operating environment.**

IP69K is achieved when the following conditions are met.

- 1) Provide appropriate wiring using communication cables with M12 connectors.
- 2) Appropriately mount the SI unit and the manifold valve.

5. **Do not use in locations with sources of surge generation.**

Installation of the product in an area around equipment (electromagnetic lifters, high-frequency induction furnaces, welding machines, motors, etc.) which generates large surge voltages could cause an internal circuitry element of the product to deteriorate or result in damage. Implement countermeasures against the surge from the generating source, and avoid contact between the lines.

6. **When directly driving a load which generates a surge voltage by relay, solenoid valve, or lamp, use a load that has an integrated surge-absorption element.**

When a surge generating load is directly driven, the product may be damaged.

7. **The product is CE marked but not immune to lightning strikes. Take measures against lightning strikes in your system.**

8. **Keep dust, wire scraps, and other foreign matter from entering the product.**

Such materials may cause equipment failure or malfunction.

9. **Mount the product in a location, which is not affected by vibration or shock.**

Failure to do so may cause equipment failure or malfunction.

10. **Do not use in direct sunlight.**

This may cause equipment failure or malfunction.

11. **Use within the ambient temperature range.**

Failure to do so may cause a malfunction.

12. **Do not use in places where radiated heat may affect the product.**

Such places are likely to cause a malfunction.



EX430 Series

Specific Product Precautions 3

Be sure to read this before handling the products.

Adjustment / Operation

Warning

1. **Do not perform operation or setting with wet hands.**
There is a risk of electrical shock.

Caution

1. **Use a watchmaker's screwdriver with a thin blade for the setting switch.**
When setting the switch, do not touch any unrelated parts. This may cause parts damage or malfunction due to a short circuit.
2. **Perform appropriate setting for the operating conditions.**
Failure to do so could result in malfunction. Refer to the Operation Manual for details on setting each switch.
3. **For details on programming and address setting, refer to the manual from the PLC manufacturer.**
The programming content related to the protocol is designed by the manufacturer of the PLC used.

Maintenance

Warning

1. **Do not disassemble, modify (including circuit board replacement), or repair this product.**
Such actions are likely to cause injuries or equipment failure.
2. **When an inspection is performed:**
 - Turn off the power supply.
 - Stop the air supply, exhaust the residual pressure in the piping, and confirm that the air has been released before performing maintenance work.

Failure to do so may result in the unexpected malfunction of system components or injury.

Caution

1. **When removing from/attaching to the valve manifold:**
 - Do not apply excessive force to the unit.
The connecting parts are firmly joined with seals.
 - Take care not to get your fingers caught.
Injury may result.
2. **Perform periodic inspection.**
Unexpected malfunction in the system composition devices is likely to occur due to malfunction of machinery or equipment.
3. **After maintenance, make sure to perform an appropriate functionality inspection.**
When abnormalities such as faulty operation occur, stop operation immediately. Unexpected malfunction in the system composition devices is likely to occur.
4. **Do not use benzine or thinner for cleaning the product.**
Damage to the surface or erasure of the display may result. Wipe off any stains with a soft cloth. If the stain is persistent, soak a cloth in a dilute solution of neutral detergent, wring it out sufficiently, wipe the product, and then finish with a dry cloth.

Other

Caution

1. Refer to the catalog of each series for Common Precautions and Specific Product Precautions for valve manifolds.

Valve

JSY5000-H

Sub-plate

Manifold Exploded View

Sub-plate Exploded View

EX430

Fittings, Plugs, Tube Releasing Tools

Manifold Options

Made to Order

Specific Product Precautions

Safety Instructions

These safety instructions are intended to prevent hazardous situations and/or equipment damage. These instructions indicate the level of potential hazard with the labels of “**Caution**,” “**Warning**” or “**Danger**.” They are all important notes for safety and must be followed in addition to International Standards (ISO/IEC)*1), and other safety regulations.

 **Caution:** **Caution** indicates a hazard with a low level of risk which, if not avoided, could result in minor or moderate injury.

 **Warning:** **Warning** indicates a hazard with a medium level of risk which, if not avoided, could result in death or serious injury.

 **Danger:** **Danger** indicates a hazard with a high level of risk which, if not avoided, will result in death or serious injury.

*1) ISO 4414: Pneumatic fluid power – General rules relating to systems.
ISO 4413: Hydraulic fluid power – General rules relating to systems.
IEC 60204-1: Safety of machinery – Electrical equipment of machines.
(Part 1: General requirements)
ISO 10218-1: Manipulating industrial robots – Safety.
etc.

Warning

1. The compatibility of the product is the responsibility of the person who designs the equipment or decides its specifications.

Since the product specified here is used under various operating conditions, its compatibility with specific equipment must be decided by the person who designs the equipment or decides its specifications based on necessary analysis and test results. The expected performance and safety assurance of the equipment will be the responsibility of the person who has determined its compatibility with the product. This person should also continuously review all specifications of the product referring to its latest catalog information, with a view to giving due consideration to any possibility of equipment failure when configuring the equipment.

2. Only personnel with appropriate training should operate machinery and equipment.

The product specified here may become unsafe if handled incorrectly. The assembly, operation and maintenance of machines or equipment including our products must be performed by an operator who is appropriately trained and experienced.

3. Do not service or attempt to remove product and machinery/equipment until safety is confirmed.

1. The inspection and maintenance of machinery/equipment should only be performed after measures to prevent falling or runaway of the driven objects have been confirmed.
2. When the product is to be removed, confirm that the safety measures as mentioned above are implemented and the power from any appropriate source is cut, and read and understand the specific product precautions of all relevant products carefully.
3. Before machinery/equipment is restarted, take measures to prevent unexpected operation and malfunction.

4. Contact SMC beforehand and take special consideration of safety measures if the product is to be used in any of the following conditions.

1. Conditions and environments outside of the given specifications, or use outdoors or in a place exposed to direct sunlight.
2. Installation on equipment in conjunction with atomic energy, railways, air navigation, space, shipping, vehicles, military, medical treatment, combustion and recreation, or equipment in contact with food and beverages, emergency stop circuits, clutch and brake circuits in press applications, safety equipment or other applications unsuitable for the standard specifications described in the product catalog.
3. An application which could have negative effects on people, property, or animals requiring special safety analysis.
4. Use in an interlock circuit, which requires the provision of double interlock for possible failure by using a mechanical protective function, and periodical checks to confirm proper operation.

Caution

1. The product is provided for use in manufacturing industries.

The product herein described is basically provided for peaceful use in manufacturing industries.
If considering using the product in other industries, consult SMC beforehand and exchange specifications or a contract if necessary.
If anything is unclear, contact your nearest sales branch.

Limited warranty and Disclaimer/ Compliance Requirements

The product used is subject to the following “Limited warranty and Disclaimer” and “Compliance Requirements”.

Read and accept them before using the product.

Limited warranty and Disclaimer

1. The warranty period of the product is 1 year in service or 1.5 years after the product is delivered, whichever is first.*2)
Also, the product may have specified durability, running distance or replacement parts. Please consult your nearest sales branch.
2. For any failure or damage reported within the warranty period which is clearly our responsibility, a replacement product or necessary parts will be provided.
This limited warranty applies only to our product independently, and not to any other damage incurred due to the failure of the product.
3. Prior to using SMC products, please read and understand the warranty terms and disclaimers noted in the specified catalog for the particular products.

*2) Vacuum pads are excluded from this 1 year warranty.

A vacuum pad is a consumable part, so it is warranted for a year after it is delivered.
Also, even within the warranty period, the wear of a product due to the use of the vacuum pad or failure due to the deterioration of rubber material are not covered by the limited warranty.

Compliance Requirements

1. The use of SMC products with production equipment for the manufacture of weapons of mass destruction (WMD) or any other weapon is strictly prohibited.
2. The exports of SMC products or technology from one country to another are governed by the relevant security laws and regulations of the countries involved in the transaction. Prior to the shipment of a SMC product to another country, assure that all local rules governing that export are known and followed.

Caution

SMC products are not intended for use as instruments for legal metrology.

Measurement instruments that SMC manufactures or sells have not been qualified by type approval tests relevant to the metrology (measurement) laws of each country. Therefore, SMC products cannot be used for business or certification ordained by the metrology (measurement) laws of each country.

Safety Instructions

Be sure to read the “Handling Precautions for SMC Products” (M-E03-3) and “Operation Manual” before use.